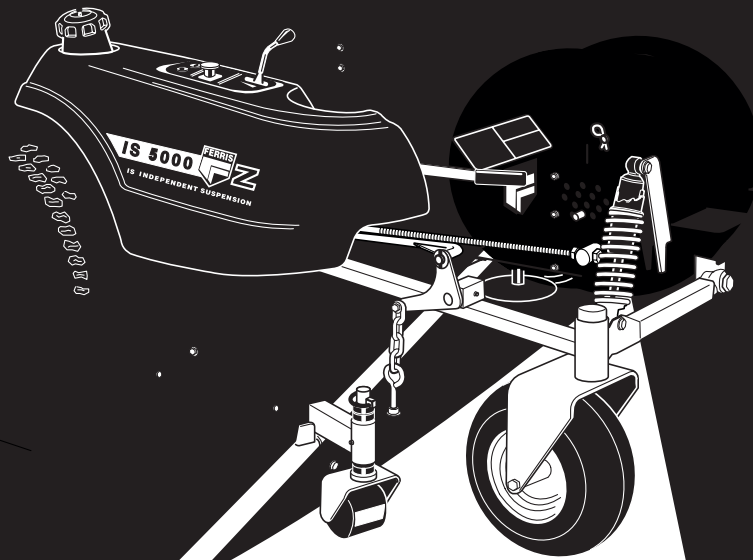




# ***OPERATOR'S MANUAL***

## ***IS5000Z Series Zero-Turn Riding Mower***



<b>Tractor:</b>	<b>Mower Deck:</b>
<b>Model</b>	<b>Model</b>
IS5000Z/C31D	5000/72
IS5000Z/C31DCE	5000/72R
IS5000ZC31D61CE	5000/61R
IS5000Z/D34	

**Ferris Industries**  
5375 North Main Street  
Munnsville, NY 13409  
800-933-6175

**22902**  
Revision 06  
Rev. Date: 4/2004  
TP 100-7060-06-5Z-F



# Table of Contents

<b>Safety Rules &amp; Information .....</b>	<b>2</b>	<b>Troubleshooting, Adjustments &amp; Service .....</b>	<b>30</b>
<b>Identification Numbers .....</b>	<b>7</b>	Troubleshooting the Rider .....	30
<b>Features &amp; Controls .....</b>	<b>8</b>	Troubleshooting the Mower .....	31
Control Functions .....	8	Seat Adjustment .....	32
Safety Interlock System .....	10	Ground Speed Control Lever Adjustment .....	32
<b>Operating the Zero Turn Rider .....</b>	<b>12</b>	Speed Balancing Adjustment .....	32
General .....	12	Neutral Adjustment .....	33
Checks Before Starting .....	12	Neutral Position & Return Spring Adjustment .....	33
Priming the Fuel System (diesel model only) .....	13	Parking Brake Adjustment .....	34
Starting the Engine .....	14	Front Suspension Adjustment .....	35
Stopping the Tractor and Engine .....	14	Rear Suspension Adjustment .....	35
Driving the Tractor .....	14	Mowing Height Adjustment .....	36
Mowing .....	15	Deck Leveling Adjustment .....	36
Pushing the Rider by Hand .....	15	Belt Removal & Replacement .....	38
Zero Turn Driving Practice .....	16	Mower Deck Drive Belt .....	38
Storage (diesel model) .....	18	Clutch Drive Belt .....	39
Starting After Long Term Storage (diesel model) .....	18	Pump Drive Belt .....	40
Diesel Fuel Recommendations .....	18	Gearbox Maintenance .....	41
Storage (gas model) .....	19	Check Gearbox Oil Level .....	41
Starting After Long Term Storage (gas model) .....	19	Change Gearbox Oil .....	41
<b>Regular Maintenance .....</b>	<b>20</b>	Battery Service .....	42
Maintenance Schedule .....	20	Checking the Battery Voltage .....	42
Checking Tire Pressures .....	20	Charging A Completely	
Checking/Adding Fuel .....	21 & 22	Discharged Battery .....	42
Fuel Filter .....	21 & 22	Jump Starting with	
Oil & Filter Change .....	23	Auxiliary (Booster) Battery .....	42
Check / Change Air Filter .....	23	Common Replacement Parts .....	44
Check Hydraulic Oil Level .....	23		
Check Engine Coolant Level .....	24 & 25	<b>Lawn Care &amp; Mowing Information .....</b>	<b>LC—1</b>
Change Engine Coolant .....	24 & 25	<b>International Symbols .....</b>	<b>LC—8</b>
Clean Radiator, Screen & Oil Cooler .....	24 & 25	<b>Technical Manuals .....</b>	<b>LC—8</b>
Check Warning Lights and Alarm .....	25		
Lubrication .....	26		
Battery Maintenance .....	28		
Checking Battery Fluid .....	28		
Cleaning the Battery and Cables .....	28		
Servicing the Mower Blades .....	29		

*NOTE: In this manual, "left" and "right" are referred to as seen from the operating position.*

## WARNING

You must read, understand and comply with all safety and operating instructions in this manual before attempting to set-up and operate your machine.

Failure to comply with all safety and operating instructions can result in loss of machine control, serious personal injury to you and / or bystanders, and risk of equipment and property damage. The triangle in the text signifies important cautions or warnings which must be followed.

## WARNING

**Engine exhaust from this product contains chemicals known, in certain quantities, to cause cancer, birth defects, or other reproductive harm.**

# Safety Rules & Information



Read these safety rules and follow them closely. Failure to obey these rules could result in loss of control of unit, severe personal injury or death to you, or bystanders, or damage to property or equipment. **This mowing deck is capable of amputating hands and feet and throwing objects.** The triangle in text signifies important cautions or warnings which must be followed.

## TRAINING

- Read, understand, and follow all instructions in the manual and on the unit before starting. If the operator(s) or mechanic(s) can not read English it is the owner's responsibility to explain this material to them.
- Become familiar with the safe operation of the equipment, operator controls, and safety signs.
- All operators and mechanics should be trained. The owner is responsible for training the users.
- Only allow responsible adults, who are familiar with the instructions, to operate the unit.
- Never let children or untrained people operate or service the equipment. Local regulations may restrict the age of the operator.

- The owner/user can prevent and is responsible for accidents or injuries occurring to themselves, other people or property.
- Data indicates that operators, age 60 years and above, are involved in a large percentage of riding mower-related injuries. These operators should evaluate their ability to operate the riding mower safely enough to protect themselves and others from serious injury.

## PREPARATION

- Evaluate the terrain to determine what accessories and attachments are needed to properly and safely perform the job. Use only accessories and attachments approved by the manufacturer.
- Wear appropriate clothing including safety shoes, safety glasses and ear protection. Long hair, loose clothing or jewelry may get tangled in moving parts.
- Inspect the area where the equipment is to be used and remove all objects such as rocks, toys and wire, which can be thrown by the machine.
- Use extra care when handling gasoline and other fuels. They are flammable and vapors are explosive.
  - a) Use only an approved container.
  - b) Never remove fuel cap or add fuel with the engine running. Allow engine to cool before refueling. Do not smoke.
  - c) Never refuel or drain the machine indoors.
- Check that operator's presence controls, safety switches and shields are attached and functioning properly. Do not operate unless they are functioning properly.

## OPERATION

- Never run an engine in an enclosed area.
- Mow only in the daylight or with good artificial light, keeping away from holes and hidden hazards.
- Be sure all drives are in neutral and parking brake is engaged before starting engine. Only start engine from the operator's position. Use seat belts if provided.
- Be sure of your footing while using pedestrian controlled equipment, especially when backing up. Walk, don't run. Reduced footing could cause slipping.
- Slow down and use extra care on hillsides. Be sure to travel in the recommended direction on hillsides. Turf conditions can affect the machines stability. Use caution when operating near drop-offs.
- Do not mow in reverse unless absolutely necessary. Always look down and behind before and while traveling in reverse.
- Be aware of the mower discharge direction and do not point it at anyone. Do not operate the mower without either the entire grass catcher or the deflector in place.
- Slow down and use caution when making turns and when changing directions on slopes.
- Never raise deck with the blades running.
- Never leave a running unit unattended. Always disengage the PTO, set parking brake, stop engine, and remove keys before dismounting. Keep hands and feet away from the cutting units.

## Operation - Con't.

- Turn off the PTO switch to disengage the blades when not mowing.
- Never operate with guards not securely in place. Be sure all interlocks are attached, adjusted properly and functioning properly.
- Never operate with the discharge deflector raised, removed or altered, unless using a grass catcher.
- Do not change the engine governor setting or over-speed the engine.
- Stop on level ground, lower implements, disengage drives, engage parking brake, shut off engine before leaving the operator's position for any reason including emptying the grass catchers or unclogging the chute.
- Stop equipment and inspect blades after striking objects or abnormal vibration occurs. Make necessary repairs before resuming operations.
- Keep hands and feet away from the cutting units.
- Look behind and down before backing up to be sure of a clear path.
- Never carry passengers and keep pets and bystanders away.
- Do not operate the unit while under the influence of alcohol or drugs.
- Slow down and use caution when making turns and crossing roads and sidewalks. Stop blades if not mowing.
- Use care when loading or unloading the machine into a trailer or truck.
- Use care when approaching blind corners, shrubs, trees or other objects that may obscure vision.
- To reduce fire hazard, keep unit free of grass, leaves & excess oil. Do not stop or park over dry leaves, grass or combustible materials.
- The engine in this unit is not factory equipped with a spark arrester. It is a violation of California Public Resource Code Section 4442 to use or operate the engine on or near any forest-covered, brush-covered, or grass-covered land unless the exhaust system is equipped with a spark arrester meeting any applicable local or state laws. Other states or federal area may have similar laws.
- OSHA regulations may require the use of hearing protection when exposed to sound levels greater than 85 dBA for an 8 hour time period.

## CAUTION



**This machine produces sound levels in excess of 85 dBA at the operator's ear and can cause hearing loss though extended periods of exposure.**

**Wear hearing protection when operating this machine.**

## SLOPE OPERATION

Slopes are a major factor related to loss-of-control and tip-over accidents, which can result in severe injury or death. All slopes require extra caution. If you cannot back up the slope or if you feel uneasy on it, do not drive on it.

## WARNING

**Never operate on slopes greater than 20° (36.4 percent) which is a rise of 7-1/4 feet (220 cm) vertically in 20 feet (607 cm) horizontally.**

Select slow ground speed before driving onto slope. In addition to front and rear weights, use extra caution when operating on slopes with rear-mounted grass catcher.

Mow UP and DOWN the slope, never across the face, use caution when changing directions and **DO NOT START OR STOP ON SLOPE.**

### Do

- Mow up and down slopes, not across.
- Remove obstacles such as rocks, tree limbs, etc.
- Watch for holes, ruts, or bumps. Uneven terrain could overturn the unit. Tall grass can hide obstacles.
- Use slow speed. Choose a slow speed so that you will not have to stop or change speed while on the slope.
- Use extra care with grass catchers or other attachments. These can change the stability of the unit.
- Keep all movement on the slopes slow and gradual. Do not make sudden changes in speed or direction.
- See your authorized dealer for recommendations of available weights to improve stability.

### Do Not

- *Do not* start or stop on a slope. If tires lose traction, disengage the blade(s) and proceed slowly straight down the slope.
- *Do not* turn on slopes unless necessary, and then, turn slowly and gradually downhill, if possible.
- *Do not* mow near drop-offs, ditches, or embankments. The operator could lose footing or balance or mower could suddenly turn over if a wheel is over the edge of a cliff or ditch, or if an edge caves in.
- *Do not* mow on wet grass. Reduced footing or traction could cause sliding.
- *Do not* try to stabilize the unit by putting your foot on the ground.
- *Do not* mow excessively steep slopes.
- *Do not* use grass catcher on steep slopes.

# Safety Rules & Information

---

## CHILDREN

Tragic accidents can occur if the operator is not alert to the presence of children. Children are often attracted to the unit and the mowing activity. Never assume that children will remain where you last saw them.

- Keep children out of the mowing area and under the watchful care of another responsible adult.
- Be alert and turn unit off if children enter the area.
- Before and during reverse operation, look behind and down for small children.
- Never carry children. They may fall off and be seriously injured or interfere with safe unit operation.
- Never allow children to operate the unit.
- Use extra care when approaching blind corners, shrubs, trees, or other objects that may obscure vision.

---

## MAINTENANCE AND STORAGE

- Always observe safe refueling and fuel handling practices when refueling the unit after transportation or storage.
- Always follow the engine manual instructions for storage preparations before storing the unit for both short and long term periods.
- Always follow the engine manual instructions for proper start-up procedures when returning the unit to service.
- Never store the machine or fuel container inside where there is an open flame, such as in a water heater. Allow unit to cool before storing.
- Shut off fuel while storing or transporting. Do not store fuel near flames or drain indoors.
- Keep all hardware, especially blade attachment bolts, tight and keep all parts in good working condition. Replace all worn or damaged decals.
- Never tamper with safety devices. Check their proper operation regularly.
- Disengage drives, lower implement, set parking brake, stop engine and remove key or disconnect spark plug wire. Wait for all movement to stop before adjusting, cleaning or repairing.
- Clean grass and debris from cutting units, drives, mufflers, and engine to prevent fires. Clean up oil or fuel spillage.
- Let engine cool before storing and do not store near flame.
- Stop and inspect the equipment if you strike an object. Repair, if necessary, before restarting.
- Never make adjustments or repairs with the engine running unless specified otherwise.
- Park machine on level ground. Never allow untrained personnel to service machine.
- Use jack stands to support components when required.

## EMISSIONS

- Engine exhaust from this product contains chemicals known, in certain quantities, to cause cancer, birth defects, or other reproductive harm.
- Look for the relevant Emissions Durability Period and Air Index information on the engine emissions label.

- Carefully release pressure from components with stored energy. (eg. springs)
- Disconnect battery or remove spark plug wire before making any repairs. Disconnect the negative terminal first and the positive last. Reconnect positive first and negative last.
- Use care when checking blades. Wrap the blade(s) or wear gloves, and use caution when servicing them. Only replace blades. Never straighten or weld them.
- Keep hands and feet away from moving parts.
- Charge batteries in an open well ventilated area, away from spark and flames. Unplug charger before connecting or disconnecting from battery. Wear protective clothes and use insulated tools.
- Keep all parts in good working condition and all hardware tightened. Replace all worn or damaged decals.
- Grass catcher components are subject to wear, damage, and deterioration, which could expose moving parts or allow objects to be thrown. Frequently check components and replace with manufacturer's recommended parts, when necessary.
- Check brake operation frequently. Adjust and service as required.
- Use only factory authorized replacement parts when making repairs.
- Always comply with factory specifications on all settings and adjustments.
- Only authorized service locations should be utilized for major service and repair requirements.
- Never attempt to make major repairs on this unit unless you have been properly trained. Improper service procedures can result in hazardous operation, equipment damage and voiding of manufacturer's warranty.

**⚠️ WARNING**

**Hydraulic fluid escaping under pressure may have sufficient force to penetrate skin and cause serious injury.**

If foreign fluid is injected into the skin it must be surgically removed within a few hours by a doctor familiar with this form of injury or gangrene may result.

Keep body and hands away from pin holes or nozzles that eject hydraulic fluid under high pressure. Use paper or cardboard and not hands to search for leaks.

Make sure all hydraulic fluid connections are tight and all hydraulic hoses and lines are in good condition before applying pressure to the system.

If leaks occur, have the unit serviced immediately by your authorized dealer.

**⚠️ WARNING**

**STORED ENERGY DEVICE: Improper release of springs can result in serious personal injury.**

Spring should be removed by an authorized dealer only.

**⚠️ WARNING**

**STORED ENERGY DEVICE: Engine Radiator (Water-Cooled Models Only)**

To prevent serious bodily injury from hot coolant or steam blow-out, never attempt to remove the radiator cap while the engine is running. Stop the engine and wait until it is cool. Even then, use extreme care when removing cap.

**NOTES**

---

---

---

---

---

---

---

---

---

---

---

---

---

---

---

---

---

---

---

---

---

---

---

---

---

---

# Safety Decals

## SAFETY DECALS

This unit has been designed and manufactured to provide you with the safety and reliability you would expect from an industry leader in outdoor power equipment manufacturing.

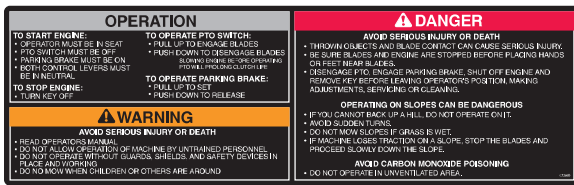
Although reading this manual and the safety instructions it contains will provide you with the necessary basic knowledge to operate this equipment safely and effectively, we have placed several safety labels on the unit to remind you of this important information while you are operating your unit.

All DANGER, WARNING, CAUTION and instructional messages on your mower should be carefully read and obeyed. Personal bodily injury can result when these instructions are not followed. The information is for your safety and it is important! The safety decals below are on your unit.

If any of these decals are lost or damaged, replace them at once. See your local dealer for replacements.

These labels are easily applied and will act as a constant visual reminder to you, and others who may use the equipment, to follow the safety instructions necessary for safe, effective operation.

## NORTH AMERICAN MODELS



Decal - Instruction/Safety  
Part No. 47540



Decal - Warning  
Part No. 20337

## CE MODELS



Decal - Warning  
Part No. 1723175



Decal - Warning  
Part No. 61042



Decal - Hot Surface  
Part No. 1704473

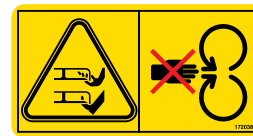
## ALL MODELS



Decal - Danger  
Part No. 1704277



Decal - Danger  
Part No. 1704276



Decal - Danger, Rotating Blades  
Part No. 1720389



## SAFETY ICONS

### Warning: Read Operator's Manual.

Read and understand the Operator's Manual before using this machine.



### Danger: Machine Rollover.

Do not use this machine on slopes greater than 10°.



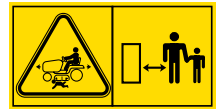
### Danger: Thrown Objects.

This machine is capable of throwing objects and debris. Keep bystanders away.



### Danger: Dismemberment.

This machine can amputate limbs. Keep bystanders and children away when engine is running.



### Warning: Remove Key Before Servicing.

Remove the key and consult technical literature before performing repairs or maintenance.



### Danger: Dismemberment.

This mower deck can amputate limbs. Keep hands and feet away from blades.

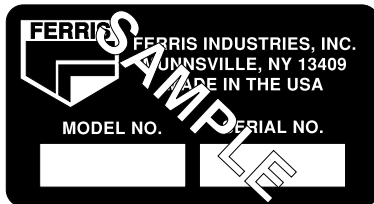


### Danger: Dismemberment.

This machine can amputate limbs. Keep hands and fingers away from rotating parts.



## Identification Numbers



North American Models



CE Models

When contacting your authorized dealer for replacement parts, service, or information you **MUST** have these numbers.

Record your model/serial number and engine serial numbers on the space provided for easy access. These numbers can be found in the locations shown.

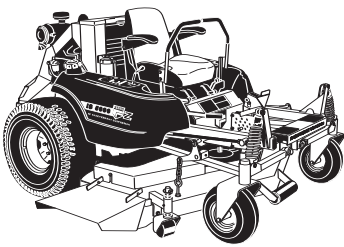
*NOTE: For location of engine identification numbers, refer to the engine owner's manual.*



Mower Deck Identification Tag

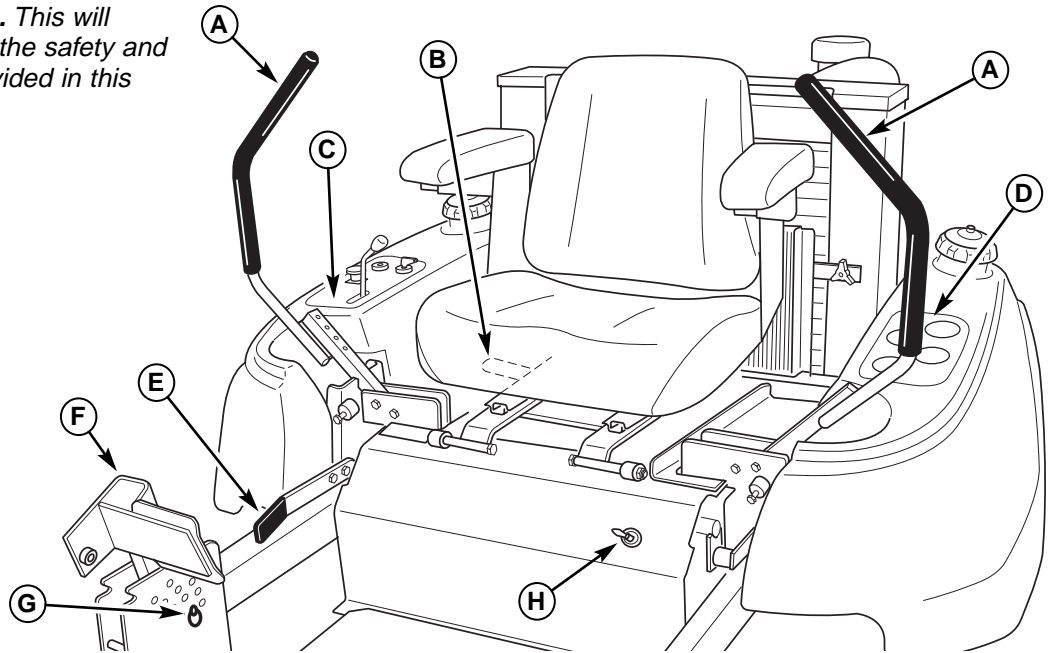
Tractor Identification Tag

PRODUCT REFERENCE DATA	
Unit Model Number	Unit SERIAL Number
Mower Deck Model Number	Mower Deck SERIAL Number
Dealer Name	Date Purchased
ENGINE REFERENCE DATA	
Engine Make	Engine Model
Engine Type/Spec.	Engine Code/Serial Number



# Features & Controls of the Zero Turn Rider

Please take a moment and familiarize yourself with the name, location, and function of the following. This will enable you to understand the safety and operating instructions provided in this manual.



**Figure 1. CONTROL FUNCTIONS**

The information below briefly describes the function of the individual controls. Starting, stopping, driving, and mowing require the combined use of several controls applied in specific sequences. To learn what combination and sequence of controls to use for various tasks see the *OPERATION* section.

## A. Ground Speed Control Levers

These levers control the ground speed of the rider. The left lever controls the left rear drive wheel and the right lever controls the right rear drive wheel.

Moving a lever forward increases the FORWARD speed of the associated wheel, and pulling back on a lever increases the REVERSE speed.

*Note: The further a lever is moved away from the neutral position the faster the drive wheel will turn.*

See the *Operating the Zero Turn Rider* section, page 16, for steering instructions.

## B. Seat Adjustment Lever

The seat can be adjusted forward and back. Move the lever forward, position the seat as desired, and release the lever to lock the seat in position.

## C. Control Panel

The control panel houses the starting, engine speed and PTO controls. See Page 9 for more details.

## D. Instrument Panel

The instrument panel shows a variety of engine operation and status information. See Page 9 for more details.

## E. Parking Brake Handle

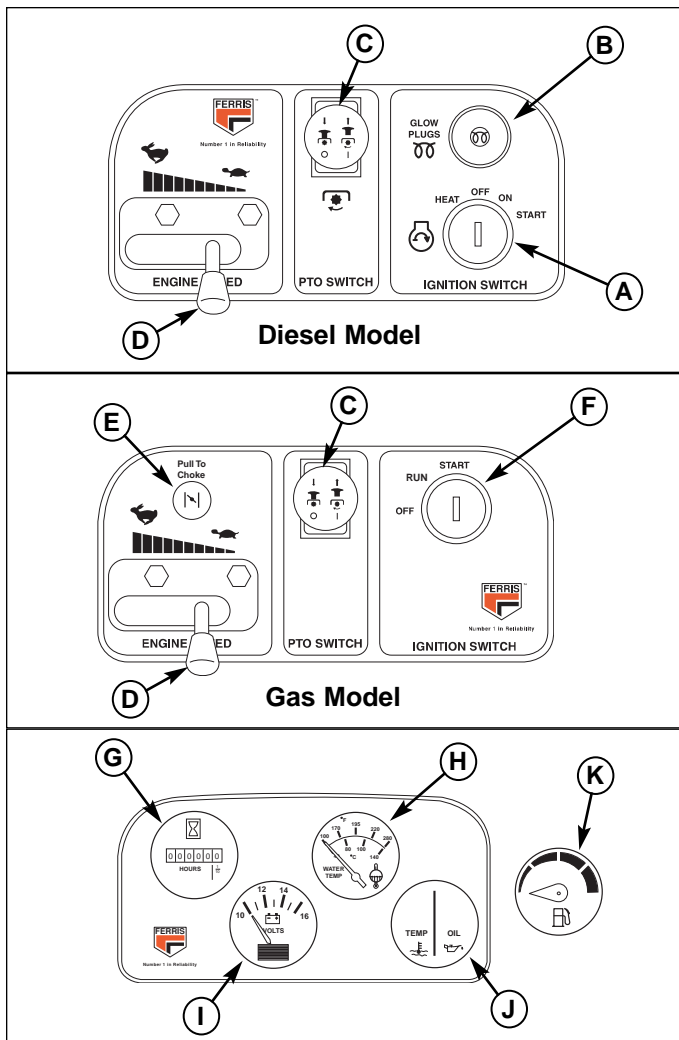
The parking brake is applied by pulling UP on the parking brake handle until it locks over-center. To release the parking brake, push the handle DOWN.

## F & G. Deck Lift Pedal & Cutting Height Adjustment Pin

These control the cutting height of the mower deck. Depress the pedal until it locks into the TRANSPORT position. Place the adjustment pin in the desired cutting height and release the lift pedal.

## H. Fuel Tank Selection Valve (Gas Model Only)

Turning the handle to the desired position determines which tank will be supplying fuel. With the handle pointing towards the left, it will draw fuel from the left-hand tank. With the handle pointed towards the right, it will draw fuel from the right-hand fuel tank. With the handle pointing towards the operator, it will shut off fuel flow to the engine.



**Figure 2. Control & Gauge Panels**

- |                        |                      |
|------------------------|----------------------|
| A. Ignition Switch     | G. Hourmeter         |
| B. Glow Plug Indicator | H. Water Temp. Gauge |
| C. PTO Switch          | I. Voltmeter         |
| D. Throttle Control    | J. Indicator Lights  |
| E. Choke Control       | K. Fuel Level Gauge  |
| F. Ignition Switch     |                      |

## A. Ignition Switch (Diesel)

The ignition switch starts and stops the engine, it has four positions:

- HEAT Heats the glow plugs.
- OFF Stops the engine and shuts off the electrical system.
- ON Allows the engine to run and powers the electrical system.
- START Cranks the engine for starting.

*NOTE: Never leave the ignition switch in the ON position with the engine stopped—this drains the battery.*

## B. Glow Plug Indicator (Diesel)

Indicates that the glow plugs are heating. Holding the ignition key in the “HEAT” position until indicator starts to glow, then turn the key to start.

## C. PTO (Power Take Off) Switch

The PTO switch engages and disengages the mower. Pull UP on the switch to engage the mower, and push DOWN to disengage the mower.

## D. Throttle Control

Moving the throttle control fully forward is FULL throttle position. Always operate the unit at FULL throttle when mowing.

## E. Choke Control (Gas)

Pulling the round choke control knob (I) out fully chokes the engine for cold starts. (A warm engine may not require choking.)

## F. Ignition Switch (Gas)

The ignition switch starts and stops the engine, it has three positions:

- OFF Stops the engine and shuts off the electrical system.
- RUN Allows the engine to run and powers the electrical system.
- START Cranks the engine for starting.

*NOTE: Never leave the ignition switch in the RUN position with the engine stopped—this drains the battery.*

## G. Hour Meter

Measures the time of the PTO being engaged.

## H. Voltmeter

Measures the battery voltage.

## I. Water Temperature Gauge

Measures the engine coolant temperature.

## J. Indicator Lights

The indicator lights will illuminate and the buzzer will sound when the ignition switch is in the “ON” position before cranking the engine. After the engine is running, the indicator lights will illuminate and the buzzer will sound when there is either low oil pressure or high coolant temperature.

## K. Fuel Level Gauge

Displays the total fuel level of both tanks on the diesel model, and fuel level of the left-hand tank only on the gas model.

## Features & Controls



### SAFETY INTERLOCK SYSTEM

This unit is equipped with safety interlock switches and other safety devices. These safety systems are present for your well being, do not attempt to bypass safety switches, and never tamper with safety devices. Check their operation regularly.

#### Operational SAFETY Checks

Your unit is equipped with a seat switch safety system. Check the seat switch operation every fall and spring with the following tests.

##### Test 1 — Engine should NOT crank if:

- PTO switch is engaged, OR
- Parking brake is not engaged, OR
- Motion control handles are not in the NEUTRAL position, OR
- Operator is not on the seat.

##### Test 2 — Engine SHOULD crank if:

- PTO switch is NOT engaged, AND
- Parking brake is engaged, AND
- Motion control handles are locked in the NEUTRAL position, AND
- Operator is on the seat.

##### Test 3 — Engine should SHUT OFF if:

- Operator rises off seat with PTO engaged, OR
- Operator rises off seat with parking brake disengaged, OR
- Operator engages PTO with parking brake engaged.
- Operator moves the control levers out of the neutral position with the parking brake engaged.

##### Test 4 — Blade Brake Check

Mower blades and mower drive belt should come to a complete stop within seven seconds after electric PTO switch is turned off (or operator rises off seat). If mower drive belt does not stop within seven seconds, see your dealer.

*NOTE: Once the engine has stopped, PTO switch must be turned off, parking brake must be engaged, and the motion control handles must be locked in the NEUTRAL position after the operator returns to the seat in order to start the engine.*

### WARNING

**If the unit does not pass a safety test, do not operate it. See your authorized dealer. Under no circumstance should you attempt to defeat the purpose of the safety interlock system.**

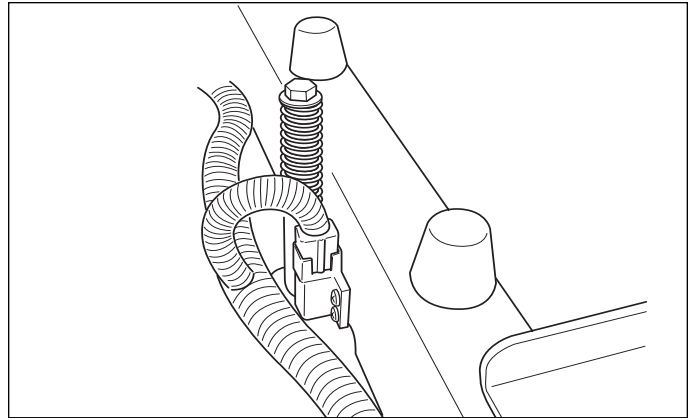


Figure 3. Seat Switch Safety System

---

---

---

---

---

---

---

---

---

---

---

---

---

---

---

---

---

---

---

---

---

---

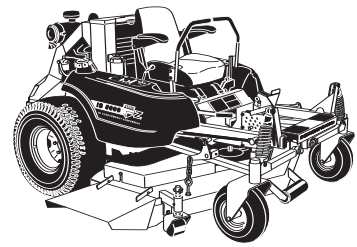
---

---

---

---

# Operating the Zero Turn Rider



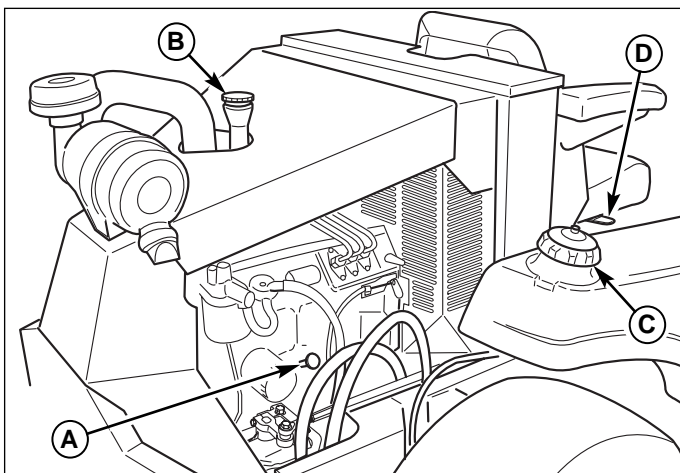
## GENERAL OPERATING SAFETY

Before first time operation:

- Be sure to read all information in the Safety and Operation sections before attempting to operate this tractor and mower.
- Become familiar with all of the controls and how to stop the unit.
- Drive in an open area without mowing to become accustomed to the unit.

## CHECKS BEFORE STARTING

- Check that crankcase is filled to full mark on dipstick. See the engine Operators Manual for instructions and oil recommendations.
- Check the radiator fluid level. See engine operator's manual for instructions.
- Check the hydraulic oil level. Refer to regular maintenance section, page 20.



**Figure 4. Pre-Start Checks**

(Diesel model shown, gas model in similar locations)

- A. Crankcase Dip Stick
- B. Oil Fill Cap
- C. Fuel Tank Cap (both sides)
- D. Seat Adjustment Lever

## **!** WARNING

Never allow passengers to ride on the unit.

Before leaving the operators position for any reason, engage the parking brake, disengage the PTO, stop the engine and remove the key.

To reduce fire hazard, keep the engine, tractor and mower free of grass, leaves and excess grease. Do not stop or park tractor over dry leaves, grass or combustible materials.

Diesel fuel is highly flammable and must be handled with care. Never fill the tank when the engine is still hot from recent operation. Do not allow open flame, smoking or matches in the area. Avoid over-filling and wipe up any spills.

- Make sure all nuts, bolts, screws and pins are in place and tight.
- Adjust the seat position, and make certain you can reach all controls from the operators position.
- Fill the fuel tanks with fresh fuel. Refer to engine manual for fuel recommendations.

## **!** DANGER

### OPERATING ON SLOPES CAN BE DANGEROUS

Never operate on slopes greater than 20° (36.4 percent) which is a rise of 7-1/4 feet (220 cm) vertically in 20 feet (607 cm) horizontally.

Operate the unit at a slow ground speed when driving onto slope.

Use extra caution when operating on slopes with rear-mounted grass catcher, and when changing directions. **DO NOT START OR STOP ON A SLOPE.**

## PRIMING THE FUEL SYSTEM

### Diesel Model Only

Priming the fuel system fills the fuel filters and removes any air bubbles from the fuel system. This must be performed before the first use, after any fuel filter maintenance or if the fuel system is run dry.

### WARNING

Fuel leaked or spilled onto hot surfaces or electrical components can cause a fire. To help prevent possible injury, turn the ignition switch off when changing fuel filter or water separator element. Clean up fuel spills immediately.

### To prime the fuel system:

#### On the water separator:

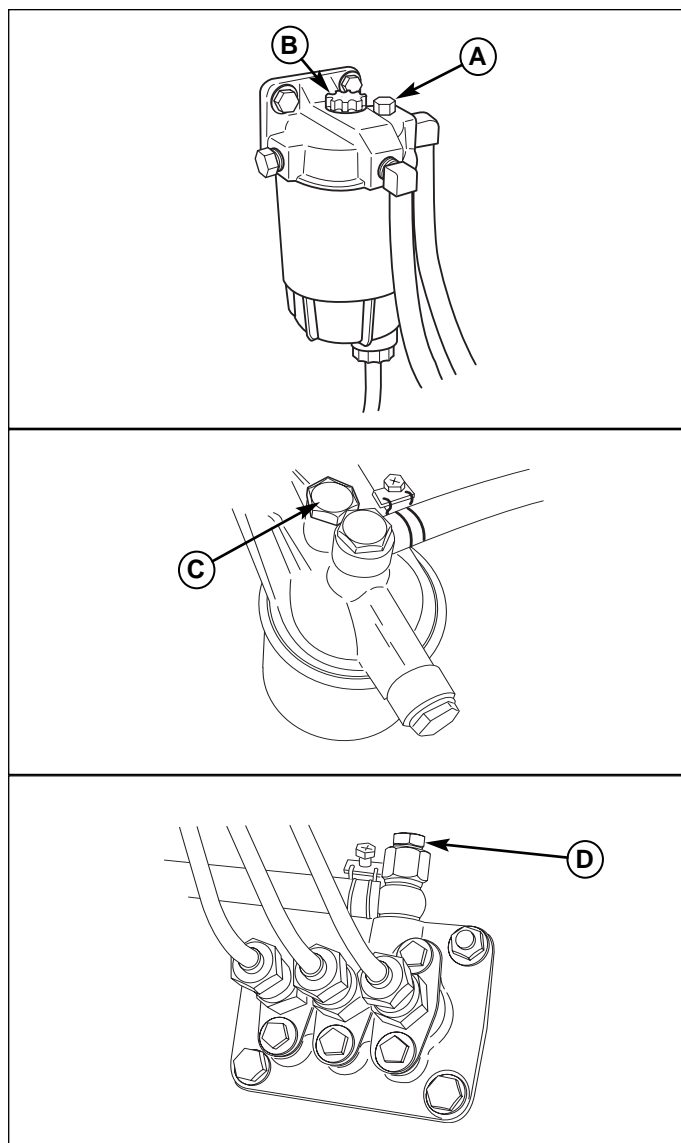
1. Using a 1/2" wrench, loosen the vent screw on the water separator 2-3 revolutions.
2. Unscrew the priming hand pump (B, Figure 5) located on top of the water separator. Operate the hand pump up and down until fuel that is free of air flows from the vent.
3. Tighten the vent screw to 4.5 ft/lbs (6 N.m.). DO NOT OVER TIGHTEN!

#### On the engine fuel filter:

1. Using the appropriate size wrench, loosen the vent screw on the engine fuel filter 2-3 revolutions.
2. Operate the hand pump up and down until fuel that is free of air flows from the vent.
3. Tighten the vent screw to 4.5 ft/lbs (6 N.m.). DO NOT OVER TIGHTEN!

#### On the engine injector pump:

1. Using a 13mm wrench, loosen the vent screw on the fuel inlet 2-3 revolutions.
2. Operate the hand pump up and down until fuel that is free of air flows from the vent.
3. Tighten the vent screw to 4.5 ft/lbs (6 N.m.). DO NOT OVER TIGHTEN!
4. Tighten the priming fuel pump finger tight.
5. Start the engine. (See STARTING THE ENGINE). If the engine will not start, further priming is necessary. If the engine starts but misfires or continues to emit smoke, further priming is necessary.
6. If the engine starts but runs rough, continue to run the engine at low idle until the engine runs smoothly.



**Figure 5. Fuel System Priming**

- A. Water Separator Vent Screw
- B. Priming Hand Pump
- C. Engine Fuel Filter Vent Screw
- D. Injector Pump Vent Screw



# Operating the Zero Turn Rider

## **WARNING**

If you do not understand how a specific control functions, or have not yet thoroughly read the **FEATURES & CONTROLS** section, do so now.

Do **NOT** attempt to operate the tractor without first becoming familiar with the location and function of **ALL** controls.

## **STARTING THE ENGINE**

### **(Diesel Model)**

1. While sitting in the operators seat, engage the parking brake and make sure the PTO switch is disengaged and the ground speed control levers are locked in the neutral position.
2. Set the throttle to middle position (set throttle to FULL when starting in cold weather)
3. Turn the key to the HEAT position and hold to activate the glow plugs (the glow plug indicator will start to glow when the glow plugs are heating.)
4. Wait until the glow plug indicator begins to glow, then turn the key to START. If the engine does not start immediately, move the throttle control to FULL.

*NOTE: Do not crank the engine continuously for more than 30 seconds. Allow the starter motor to cool for two minutes before cranking the engine again.*

5. After the engine starts, move the engine throttle control to SLOW. Warm up the engine by running it for at least a minute.
6. Move the throttle to FULL before engaging the PTO switch or driving the machine.

*NOTE: In the event of an emergency the engine can be stopped by simply turning the ignition switch to STOP. Use this method only in emergency situations. For normal engine shut down follow the procedure given in STOPPING THE TRACTOR.*

## **STARTING THE ENGINE**

### **(Gas Model)**

1. While sitting in the operators seat, engage the parking brake and make sure the PTO switch is disengaged and the motion control handles are locked in the NEUTRAL position.
2. NOTE: A warm engine may not require choking.

Set the engine throttle control to FAST throttle position. Then fully close the choke by pulling the knob OUT fully.

3. Insert the key into the ignition switch and turn it to START.

4. After the engine starts, gradually open the choke (push knob down fully).

*Warm up the engine by running it for at least a minute before engaging the PTO switch or driving the rider.*

5. **After warming the engine, ALWAYS operate the unit at FULL THROTTLE when mowing.**

*In the event of an emergency the engine can be stopped by simply turning the ignition switch to STOP. Use this method only in emergency situations. For normal engine shut down follow the procedure given in STOPPING THE RIDER.*

## **STOPPING THE TRACTOR & ENGINE**

1. Returning the ground speed control levers to the middle position will stop tractor movement. Pivot the levers outward and lock them in neutral.
2. Disengage the PTO.
3. Engage the parking brake.
4. Move the throttle control to SLOW and allow the engine to cool down for a short time.
5. Turn the ignition key to OFF. Remove the key.

## **DRIVING THE TRACTOR**

1. Sit in the seat and adjust the seat so that you can comfortably reach all of the controls and see the instrument and gauge panels.
2. Engage the parking brake.
3. Make sure the PTO switch is disengaged and the ground speed control levers are locked in the neutral position.
4. Start the engine (see STARTING THE ENGINE).
5. Disengage the parking brake and pivot the ground speed control levers inward.
6. Move the levers evenly forward to travel forward. Return them to the neutral position to stop. Note that the further the levers are moved forward the faster the tractor will travel.
7. Stop the tractor by returning the control levers to the neutral position, pivoting the levers outward to lock into the neutral position, engaging the parking brake, and stopping the engine (see STOPPING THE TRACTOR AND ENGINE).

*NOTE: See the ZERO-TURN DRIVING PRACTICE section on pages 14 & 15 for detailed instructions on driving the tractor.*



## MOWING

1. Engage the parking brake. Make sure the PTO switch is disengaged, the motion control handles are locked in the NEUTRAL position and the operator is on the seat.
2. Start the engine (see STARTING THE ENGINE).
3. Set the mower cutting height.
4. Set the throttle to FULL.
5. Engage the PTO by pulling up on the PTO switch (C, Figure 2).
6. Begin mowing. See the *Lawn Care Section* for tips on mowing patterns, lawn care, and trouble shooting information.
7. When finished, slow engine down and shut off the PTO.
8. Stop the engine (see STOPPING THE TRACTOR AND ENGINE).

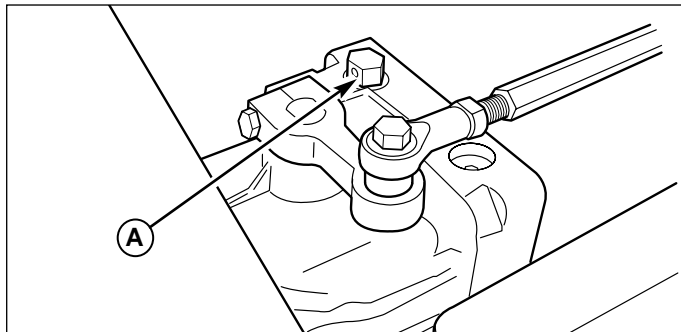
## PUSHING THE RIDER BY HAND



### DO NOT TOW RIDER

Towing the unit will cause hydraulic pump and wheel motor damage. Do not use another vehicle to push or pull this unit.

1. Refer to Figure 6 for hydraulic release valve location.
2. To open the dump valves, turn the right-hand release valve, which is located on top of the right-hand pump, counter-clockwise 2 full turns MAX. Then turn the left-hand release valve, which is located on the bottom of the left-hand pump, counter-clockwise 2 full turns MAX.
3. Disengage the parking brake. The tractor can now be pushed by hand.
4. After moving the tractor, engage the parking brake. Re-engage the pumps (drive position) by turning the release valves clockwise and tighten to 80-120 in/lbs (9-13.5 N.m.).



**Figure 6. Hydraulic Release Valve Location**

A. Hydraulic Release Valve (Right-hand side shown)

# Operating the Zero Turn Rider

## ZERO TURN DRIVING PRACTICE

The lever controls of the Zero Turn rider are responsive, and learning to gain a smooth and efficient control of the rider's forward, reverse, and turning movements will take some practice.

Spending some time going through the maneuvers shown and becoming familiar with how the unit accelerates, travels, and steers — before you begin mowing — is absolutely essential to getting the most out of the Zero Turn rider.

**Locate a smooth, flat area of your lawn** — one with plenty of room to maneuver. (Clear the area of objects, people and animals before you begin.) Operate the unit at mid-throttle during this practice session (ALWAYS operate at full throttle when mowing), and turn slowly to prevent tire slippage and damage to your lawn.

We suggest you begin with the Smooth Travel procedure to the right, and then advance through the forward, reverse, and turning maneuvers.

You must release the parking brake prior to moving the control levers inward.

## Smooth Travel

The lever controls of the Zero Turn rider are **RESPONSIVE**.

*The BEST method of handling the ground speed control levers is in three steps — as shown in Figure 3.*

FIRST place your hands onto the levers as shown.

SECOND, to go forward gradually push the levers forward with your palms.

THIRD, to speed up move the levers farther forward. To slow down smoothly, slowly move the levers toward neutral.

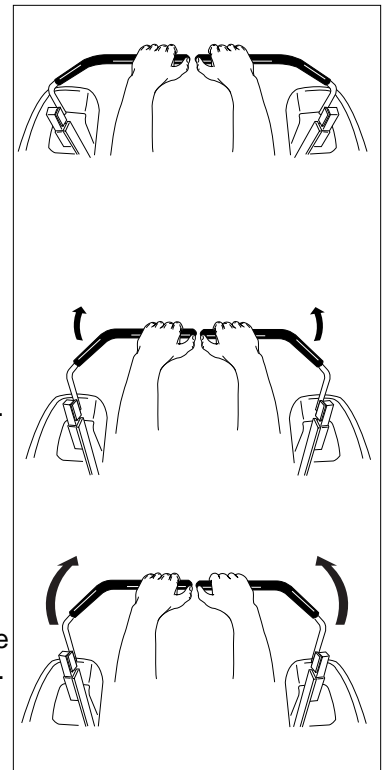


Figure 7. Move Control Levers Gradually

## BASIC DRIVING

### Forward Travel Practice

Gradually move both ground speed control levers — evenly FORWARD from neutral. Slow down and repeat.

*NOTE: Straight forward travel takes practice. If necessary, top speed can be balance-adjusted — see the Speed Balancing Adjustment in the Adjustments section located on page 26.*

### Reverse Travel Practice

LOOK DOWN & BEHIND, then gradually move both ground speed control levers evenly BACK from neutral. Slow down and repeat.

*NOTE: Practice backing up for several minutes before attempting to do so near objects. The rider turns sharply in reverse as well as forward, and backing up straight takes practice.*

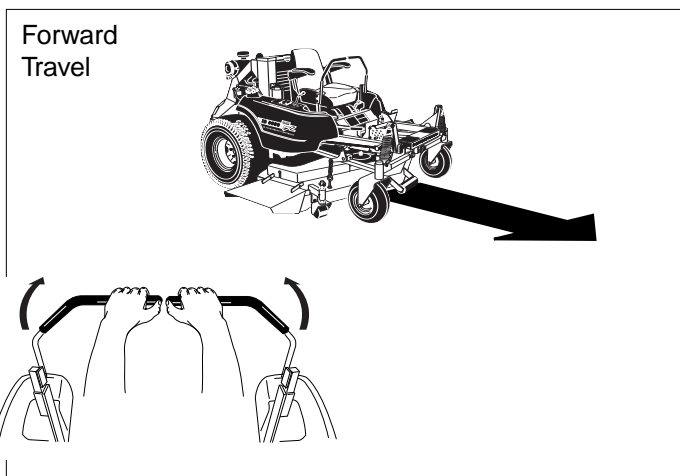


Figure 8. Forward Travel

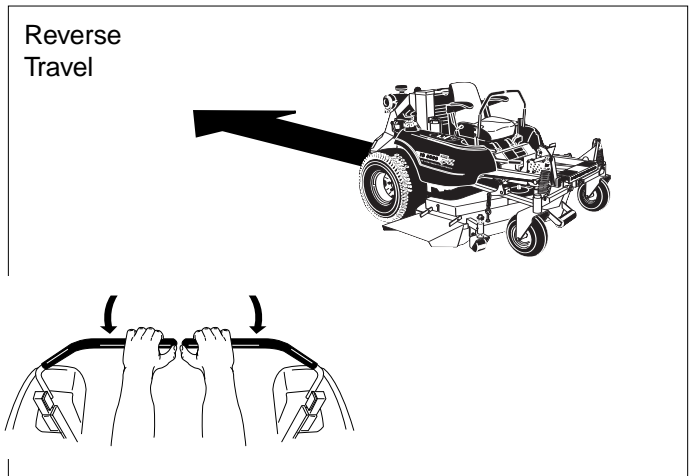


Figure 9. Reverse Travel

## Practice Turning Around a Corner

While traveling forward allow one handle to gradually return back toward neutral. Repeat several times.

*NOTE: To prevent pivoting directly on the tire tread, it is best to keep both wheels going at least slightly forward.*

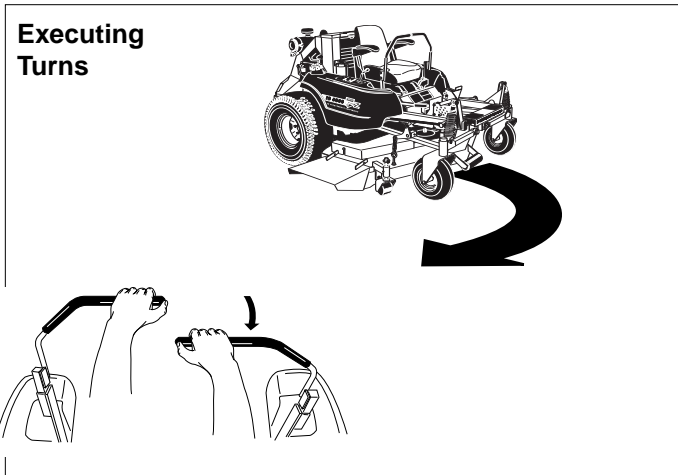


Figure 10. Turning Around a Corner

## Practice Turning In Place

To turn in place, “Zero Turn,” gradually move one ground speed control lever forward from neutral and one lever back from neutral simultaneously. Repeat several times.

*NOTE: Changing the amount each lever is pulled—forward or back, changes the “pivot point” you turn on.*

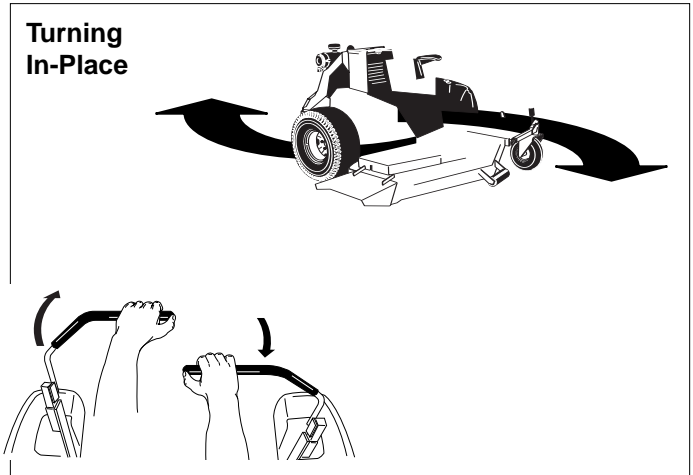


Figure 11. Turning in Place

## ADVANCED DRIVING

### Executing an End-Of-Row Zero Turn

Your Zero Turn Rider’s unique ability to turn in place allows you to turn around at the end of a cutting row rather than having to stop and Y-turn before starting a new row.

For example, to execute a right end-of-row Zero Turn:

1. Slow down at the end of the row.
2. Move the LEFT ground speed control lever forward slightly while moving the RIGHT ground speed control lever back to center and then slightly back from center.
3. Begin mowing forward again.

This technique turns the rider RIGHT and slightly overlaps the row just cut—eliminating the need to back up and re-cut missed grass.

As you become more familiar and experienced with operating the Zero Turn rider, you will learn more maneuvers that will make your mowing time easier and more enjoyable.

**Remember, the more you practice, the better your control of the Zero Turn will be!**

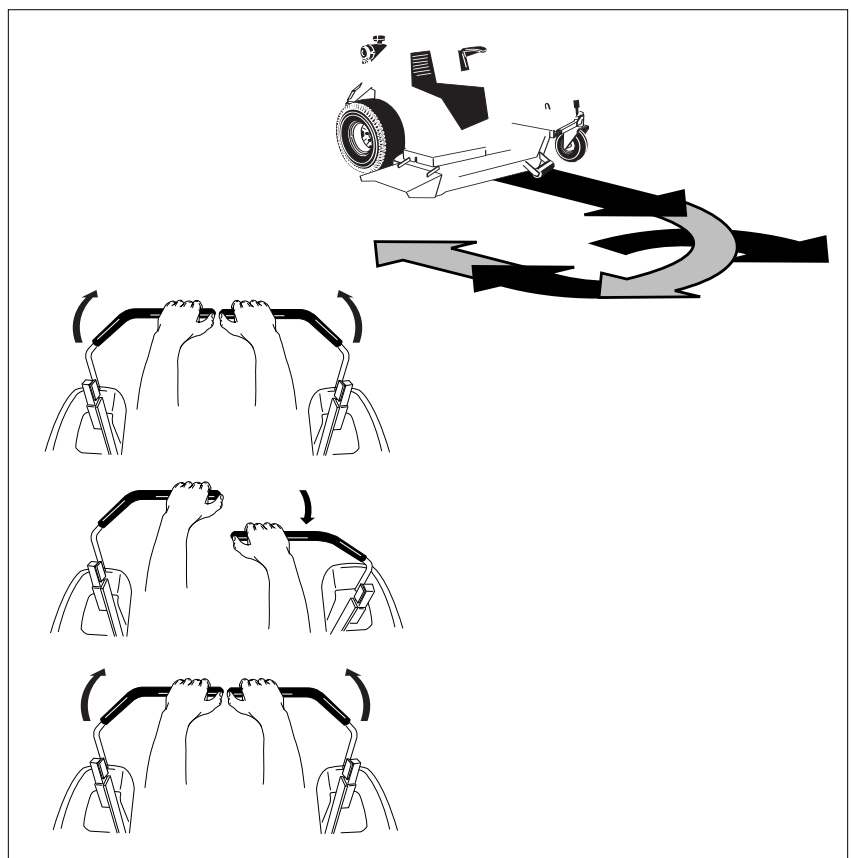


Figure 12. Executing an End-Of-Row Turn

# Operating the Zero Turn Rider

## STORAGE (Diesel model)

### Temporary Storage (30 Days Or Less)

Remember, the fuel tank will still contain some fuel, so never store the unit indoors or in any other area where fuel vapor could travel to any ignition source. Fuel vapor is also toxic if inhaled, so never store the unit in any structure used for human or animal habitation.

Here is a checklist of things to do when storing your unit temporarily or in between uses:

- Keep the unit in an area away from where children may come into contact with it. If there's any chance of unauthorized use remove the ignition key.
- If the unit can't be stored on a reasonable level surface, chock the wheels.
- Clean all grass and dirt from the mower.
- If temperature is expected to drop below 35 degrees, refer to Long Term Storage, Item 2.

### Long Term Storage (Longer Than 30 Days)

Before you store your unit for the off-season, read the Maintenance and Storage instructions in the Safety Rules section, then perform the following steps:

1. Drain crankcase oil while engine is hot and refill with a grade of oil that will be required when unit is used again.
2. Use an Antifreeze tester to check the cooling system's level of protection. Read the instructions on the Antifreeze container for the appropriate ratio of water to Antifreeze for your geographical area.
3. Prepare the mower deck for storage as follows:
  - a. Remove mower deck from the unit.
  - b. Clean underside of mower deck.
  - c. Coat all bare metal surfaces with paint or light coat of oil to prevent rusting.
4. Clean external surfaces and engine.
5. Prepare engine for storage. See engine owner's manual.
6. Clean any dirt or grass from cylinder head, engine housing and air cleaner element.
7. Cover air cleaner and exhaust outlet tightly with plastic or other waterproof material to keep out moisture, dirt and insects.
8. Completely grease and oil unit as outlined in the Regular Maintenance section.
9. Clean up unit and apply paint or rust preventative to any areas where paint is chipped or damaged.
10. Be sure the battery is filled to the proper level with water and is fully charged. Battery life will be increased if it is removed, put in a cool, dry place and fully charged about once a month. If battery is left in unit, disconnect the negative cable.
11. Drain fuel system completely or add a diesel fuel stabilizer to the fuel system. If you have chosen to use a fuel stabilizer and have not drained the fuel system, follow all safety instructions and storage precautions in this manual to prevent the possibility of fire from the ignition of diesel fumes. Remember, diesel fumes can travel to distant sources of ignition and ignite, causing risk of explosion and fire.

## WARNING

**Never store the unit, with diesel fuel in engine or fuel tank, in a heated shelter or in enclosed, poorly ventilated enclosures. Diesel fumes may reach an open flame, spark or pilot light (such as a furnace, water heater, clothes dryer, etc.) and cause an explosion.**

**Handle diesel fuel carefully. It is highly flammable and careless use could result in serious fire damage to your person or property.**

**Drain fuel outdoors into an approved container and away from open flame or sparks.**

*NOTE: Diesel fuel, if permitted to stand unused for extended periods (30 days or more), may develop gummy deposits which can adversely affect the fuel pump and injector tubes and cause engine malfunction. To avoid this condition, add a diesel fuel stabilizer to the fuel tank and run the engine a few minutes, or drain all fuel from the unit before placing it in storage.*

## STARTING AFTER LONG TERM STORAGE

Before starting the unit after it has been stored for a long period of time, perform the following steps.

1. Remove any blocks from under the unit.
2. Install the battery if it was removed.
3. Unplug the exhaust outlet and air cleaner.
4. Fill the fuel tank with fresh fuel. See engine manual for recommendations.
5. See engine owner's manual and follow all instructions for preparing engine after storage.
6. Check crankcase oil level and add proper oil if necessary. If any condensation has developed during storage, drain crankcase oil and refill.
7. Inflate tires to proper pressure. Check fluid levels.
8. Start the engine and let it run slowly. DO NOT run at high speed immediately after starting. Be sure to run engine only outdoors or in well ventilated area.

## DIESEL FUEL RECOMMENDATIONS

Fuel companies provide fuel tailored to meet the existing weather conditions. These fuels change at the start of the predominant season according to regional weather trends.

Winter fuels are tailored to give ease of starting for cold weather. Summer fuel may be somewhat heavier than winter fuel resulting in slightly better fuel economy and power. Spring and fall fuel is an average blend between winter and summer blend.

For these reasons an effort should be made to purchase fuels in such quantities that they are not carried over into the next season. Using the wrong blend of fuel can cause problems with the engine.

Refer to the engine manufacturer's manual for specific fuel recommendations.

## STORAGE (Gas Model)

### Temporary Storage (30 Days Or Less)

Remember, the fuel tank will still contain some gasoline, so never store the unit indoors or in any other area where fuel vapor could travel to any ignition source. Fuel vapor is also toxic if inhaled, so never store the unit in any structure used for human or animal habitation.

Here is a checklist of things to do when storing your unit temporarily or in between uses:

- Keep the unit in an area away from where children may come into contact with it. If there's any chance of unauthorized use, remove the spark plug (s) and put in a safe place. Be sure the spark plug opening is protected from foreign objects with a suitable cover.
- If the unit can't be stored on a reasonable level surface, chock the wheels.
- Clean all grass and dirt from the mower.
- If temperature is expected to drop below 35 degrees, refer to Long Term Storage, Item 2.

### Long Term Storage (Longer Than 30 Days)

Before you store your unit for the off-season, read the Maintenance and Storage instructions in the Safety Rules section, then perform the following steps:

1. Drain crankcase oil while engine is hot and refill with a grade of oil that will be required when unit is used again.
2. Use an Antifreeze tester to check the cooling system's level of protection. Read the instructions on the Antifreeze container for the appropriate ratio of water to Antifreeze for your geographical area.
3. Prepare the mower deck for storage as follows:
  - a. Remove mower deck from the unit.
  - b. Clean underside of mower deck.
  - c. Coat all bare metal surfaces with paint or light coat of oil to prevent rusting.
4. Clean external surfaces and engine.
5. Prepare engine for storage. See engine owner's manual.
6. Clean any dirt or grass from cylinder head cooling fins, engine housing and air cleaner element.
7. Cover air cleaner and exhaust outlet tightly with plastic or other waterproof material to keep out moisture, dirt and insects.
8. Completely grease and oil unit as outlined in the Regular Maintenance section.
9. Clean up unit and apply paint or rust preventative to any areas where paint is chipped or damaged.
10. Be sure the battery is filled to the proper level with water and is fully charged. Battery life will be increased if it is removed, put in a cool, dry place and fully charged about once a month. If battery is left in unit, disconnect the negative cable.
11. Drain fuel system completely or add a gasoline stabilizer to the fuel system. If you have chosen to use a fuel stabilizer and have not drained the fuel system, follow all safety instructions and storage precautions in this manual to prevent the possibility of fire from the ignition of gasoline fumes. Remember, gasoline fumes can travel to distant sources of ignition and ignite, causing risk of explosion and fire.

## WARNING

**Never store the unit, with gasoline in engine or fuel tank, in a heated shelter or in enclosed, poorly ventilated enclosures. Gasoline fumes may reach an open flame, spark or pilot light (such as a furnace, water heater, clothes dryer, etc.) and cause an explosion.**

**Handle gasoline carefully. It is highly flammable and careless use could result in serious fire damage to your person or property.**

**Drain fuel outdoors into an approved container and away from open flame or sparks.**

*NOTE: Gasoline, if permitted to stand unused for extended periods (30 days or more), may develop gummy deposits which can adversely affect the engine carburetor and cause engine malfunction. To avoid this condition, add a gasoline stabilizer to the fuel tank and run the engine a few minutes, or drain all fuel from the unit before placing it in storage.*

## STARTING AFTER LONG TERM STORAGE

Before starting the unit after it has been stored for a long period of time, perform the following steps.

1. Remove any blocks from under the unit.
2. Install the battery if it was removed.
3. Unplug the exhaust outlet and air cleaner.
4. Fill the fuel tank with fresh gasoline. See engine manual for recommendations.
5. See engine owner's manual and follow all instructions for preparing engine after storage.
6. Check crankcase oil level and add proper oil if necessary. If any condensation has developed during storage, drain crankcase oil and refill.
7. Inflate tires to proper pressure.
8. Start the engine and let it run slowly. DO NOT run at high speed immediately after starting. Be sure to run engine only outdoors or in well ventilated area





## DIESEL MODEL

### CHECKING / ADDING FUEL

#### To add fuel:

1. Remove the fuel cap.
2. Fill the tank to the bottom of the fill tube. This will leave room in the tank for fuel expansion. Refer to your engine manual for specific fuel recommendations.
3. Install and hand tighten the fuel cap.
4. Repeat same process for opposite tank.

*NOTE: The fuel tanks are tied together through a "tee" in the supply lines. By filling only one tank, the level will balance between the two tanks, effectively having 1/2 tank of fuel for each side.*

### FUEL FILTER

This unit is equipped with two fuel filters. One is a water separator/filter mounted to the radiator shroud and the other is located on the engine. The water separator should be drained every 50 hours or whenever water is visible in the bowl. Replace the fuel filters every 500 hours of operation or as required.

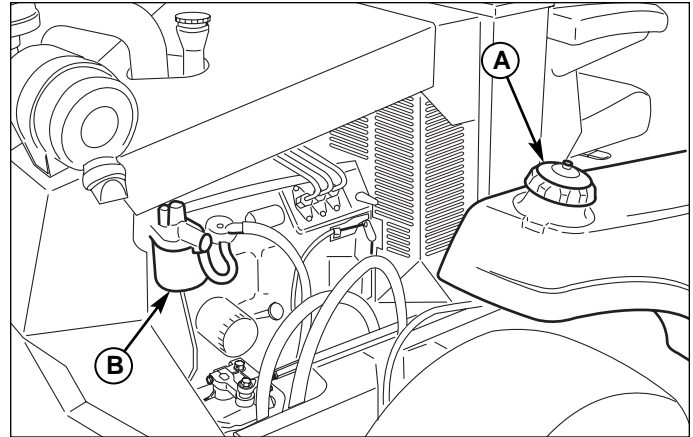
#### To drain the fuel filter:

1. Turn the engine off, set the parking brake, remove the ignition key, and wait for all moving parts to stop.
2. Allow the engine and surrounding areas to cool to room temperature.
3. Place a container under the fuel filter tube and turn the drain valve (B, Figure 15) approximately 1 turn.
4. Allow the filter to drain until all water and debris have drained out.
5. Turn the drain valve to close it when finished draining.
6. Prime the fuel system to remove any air from the filter and fuel lines. See Priming the Fuel System on page 13 for complete instructions.

### **⚠ WARNING**

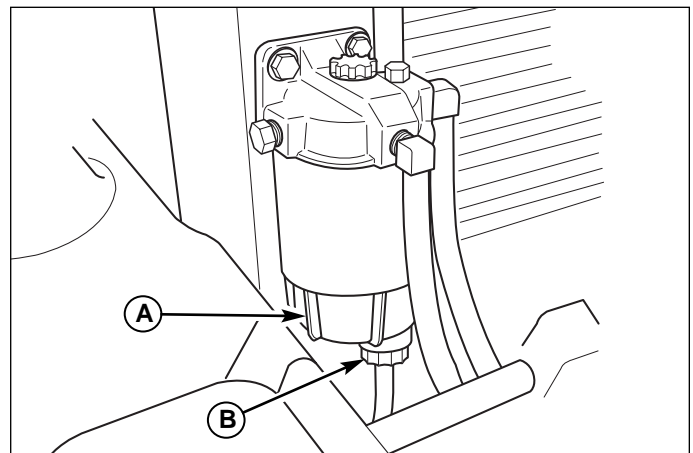
Diesel fuel is highly flammable and must be handled with care. Never fill the tank when the engine is still hot from recent operation. Do not allow open flame, smoking or matches in the area. Avoid over-filling and wipe up any spills.

Do not drain or replace fuel filter when engine is hot, as spilled fuel may ignite. Make sure the filter drain valve is fully closed before returning the unit to service.



**Figure 14. Fuel Tank Fill**

- A. Fuel Tank Cap
- B. Fuel Filter



**Figure 15. Drain Fuel Filter**

- A. Fuel Filter Bowl
- B. Drain Valve



Do not use Kerosene in place of diesel fuel. Kerosene will damage the engine.

Consult the engine manufacturer's manual for specific fuel recommendations.

### **⚠ WARNING**

Fuel leaked or spilled onto hot surfaces or electrical components can cause a fire. To help prevent possible injury, turn the ignition switch off when changing fuel filters or water separator elements. Clean up fuel spills immediately.



The water separator is under suction during normal engine operation. Ensure the drain valve is tightened securely to help prevent air from entering the fuel system.

# Regular Maintenance

---

## GAS MODEL

### CHECKING / ADDING FUEL

To add fuel:

1. Remove the fuel cap (see A, Figure 2).
2. Fill the tank to the bottom of the filler neck. This will allow for fuel expansion.

*NOTE: Do not overfill. Refer to your engine manual for specific fuel recommendations.*

3. Install and hand tighten the fuel cap.
4. Repeat same process for opposite tank.

*NOTE: The fuel supply to the engine is regulated by the tank selector valve. Therefore, the fuel gauge will only register the fuel level in the left-hand tank. It is **strongly** recommended that the **right-hand tank** is used **first** so when the tank is empty, switching over to the left-hand tank will inform the operator of the remaining fuel available.*

### FUEL FILTER

The fuel filter is located in the fuel line between fuel shut off valve and fuel pump, behind the hydraulic reservoir. If filter is dirty or clogged, replace as follows:

1. Shut off the fuel tank selection valve.
2. Disconnect the negative battery cable.
3. Place a container below the filter to catch spilled fuel.
4. Using a pliers, open and slide hose clamps from fuel filter.
5. Remove hoses from filter.
6. Install new filter in proper flow direction in fuel line.
7. Secure with hose clamps.
8. Reconnect the negative battery cable when finished.

### WARNING

Gasoline is highly flammable and must be handled with care. Never fill the tank when the engine is still hot from recent operation. Do not allow open flame, smoking or matches in the area. Avoid over-filling and wipe up any spills.

Do not remove fuel filter when engine is hot, as spilled gasoline may ignite. DO NOT spread hose clamps further than necessary. Ensure clamps grip hoses firmly over filter after installation.



Do not use gasoline containing METHANOL, gasohol containing more than 10% ethanol, gasoline additives, premium gasoline, or white gas because engine/fuel system damage could result.

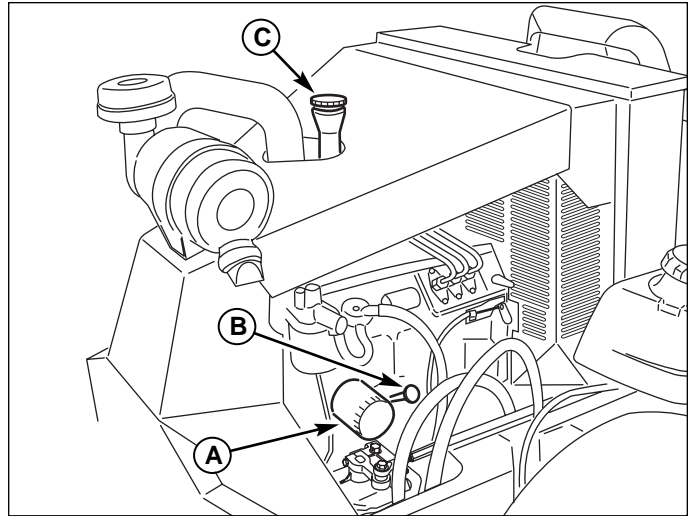


## OIL & FILTER CHANGE

Refer to Figure 16 for oil filter, dipstick and filler neck locations.

To drain the oil:

1. Place a drain pan below the engine oil pan.
2. Remove the oil drain plug and allow the engine oil to completely drain.
3. Remove and replace the oil filter
4. Reinstall the oil drain plug.
5. Refill the engine oil. See the engine owners manual for oil recommendations.



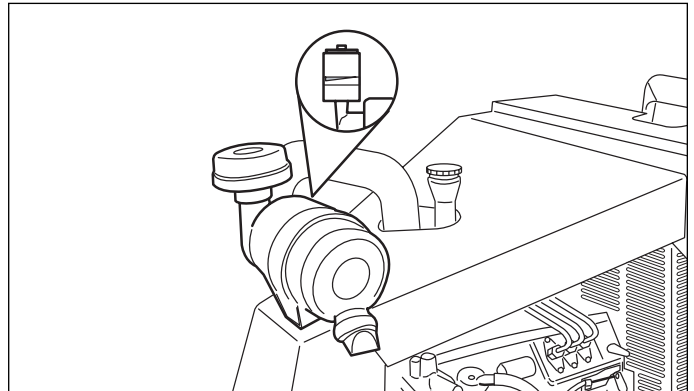
**Figure 16. Change Oil & Filter**

- A. Oil Filter
- B. Crankcase Dip Stick
- C. Oil Fill Cap

## CHECK / CHANGE AIR FILTER

Refer to the engine owners manual for specific air filter service procedures. Refer to Figure 17 for air filter and service indicator locations.

*NOTE: Service indicator is present on the diesel model only.*

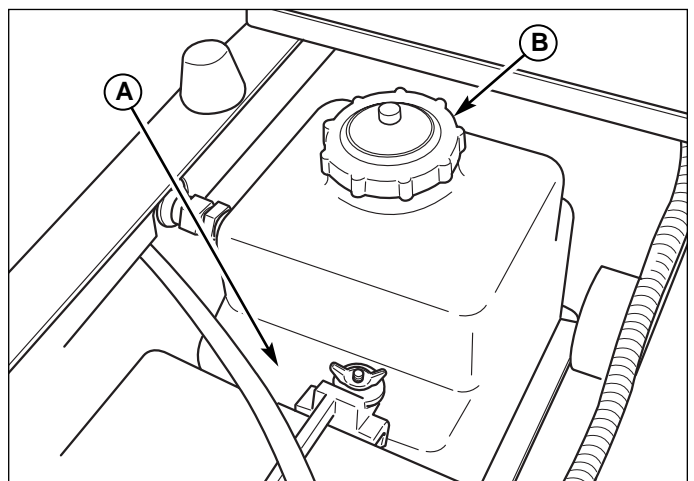


**Figure 17. Air Filter & Service Indicator**

## CHECK HYDRAULIC OIL LEVEL

*NOTE: Do not open the hydraulic oil reservoir unless oil is being added.*

1. Visually check that the hydraulic oil level is filled to the recess area (A, Figure 18) of the hydraulic oil reservoir.
3. If necessary, remove the reservoir cap (B, Figure 18) and add either Mobil 1™, 15W-50 synthetic oil or Castrol Syntec™ 5W-50 oil. **DO NOT** use conventional oils. Make sure area around the filler neck is free of dust, dirt, or other debris.



**Figure 18. Hydraulic Oil Reservoir**

- A. Tank Recess ("FULL" level)
- B. Cap

## Regular Maintenance

### CHECK ENGINE COOLANT LEVEL

#### (Diesel Model)

The engine coolant level and quality should be checked before each use, when the engine is cool and off.

1. Remove the radiator pressure cap (A, Figure 19) to check the fluid level.
2. Coolant level should be 1/2" (13mm) below the bottom of the filler tube. If coolant level is low, add coolant until level is 1/2" (13mm) below the bottom of the filler tube. Proper coolant mix is a 50/50 mixture of ethylene glycol and distilled water. See engine owners manual for engine coolant specifications.
3. Check the coolant level in the radiator overflow bottle (Figure 20). If coolant level is low, add coolant until level is at the "FULL" line. Proper coolant mix is a 50/50 mixture of ethylene glycol and distilled water. See engine owners manual for engine coolant specifications.

### CHANGE ENGINE COOLANT

#### (Diesel Model)

See engine owners manual for specific engine coolant procedures. The drain valve is located at the base of the right-hand side of the radiator.

### CLEAN RADIATOR, SCREEN & OIL COOLER

#### (Diesel Model)

Clean the radiator, screen and oil cooler fins before each use, or as required (depending on conditions) to allow proper air-flow through radiator and hydraulic oil cooler.

1. Raise the seat plate.
2. Remove the wing bolt (E) from the oil cooler mount and pivot the oil cooler (D) forward to access the radiator screen.
3. Lift the screen keeper handles (C) up and pull forward. Remove the radiator screen and flush with water or blow clean with air. Flush the radiator core with water or blow clean with air. See engine owners manual for proper radiator cleaning procedures.
4. Clean all dirt, grass, and debris from the oil cooler fins.
5. Reinstall the radiator screen. Push the screen keeper handles back and down to retain the screen.
6. Pivot the oil cooler back and reinstall the wing bolt.

## ⚠ WARNING

### PRESSURIZED SYSTEM

Hot coolant can cause serious burns. To open the cooling system filler cap, stop the engine and wait until the cooling system components are cool. Loosen the cooling system pressure cap slowly in order to relieve the pressure.

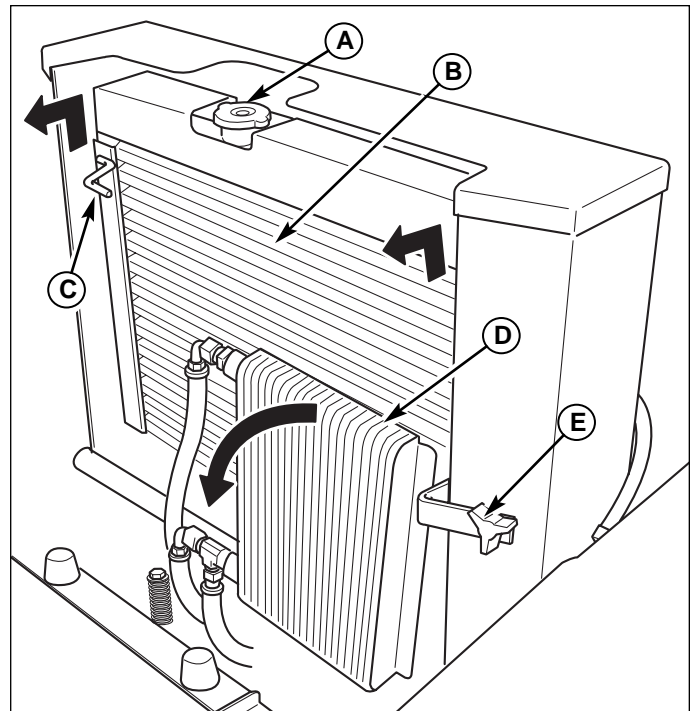


Figure 19. Radiator & Oil Cooler

- A. Radiator Pressure Cap
- B. Radiator Screen
- C. Screen Keeper Handle (LH side hidden)
- D. Hydraulic Oil Cooler
- E. Wing Bolt

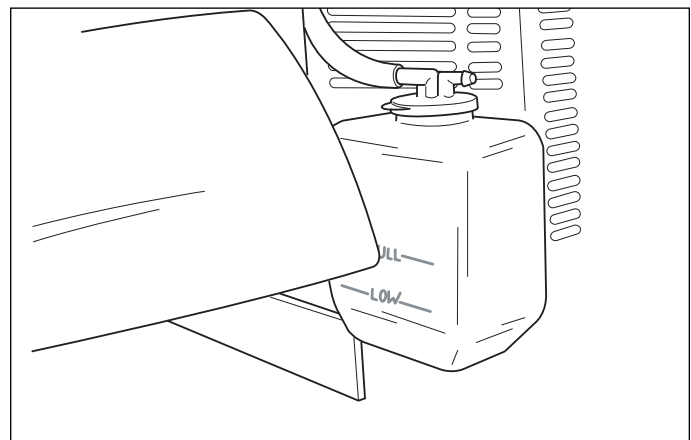


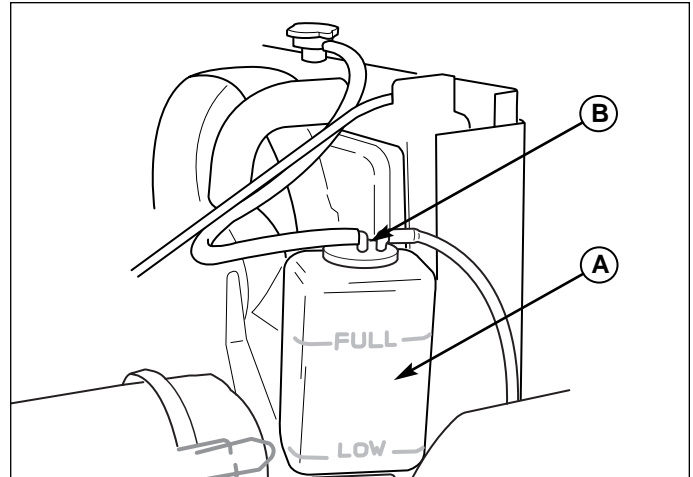
Figure 20. Radiator Overflow Bottle

## CHECK ENGINE COOLANT LEVEL

### (Gas Model)

The engine coolant level and quality should be checked before each use, when the engine is cool and off.

1. Check the coolant in the overflow reservoir (A, Figure 21). Coolant should be between the "FULL" and "LOW" marks on the tank.
2. If coolant level is below the "LOW" on the overflow reservoir, add coolant by shutting off the engine, allowing the engine to cool, removing the reservoir cap (B, Figure 21) and adding coolant. Refer to Engine coolant container for proper mix ratio of Engine coolant and distilled water.



**Figure 21. Engine Coolant and Overflow**

- A. Coolant Overflow Reservoir
- B. Reservoir Cap

## CHANGE ENGINE COOLANT

### (Gas Model)

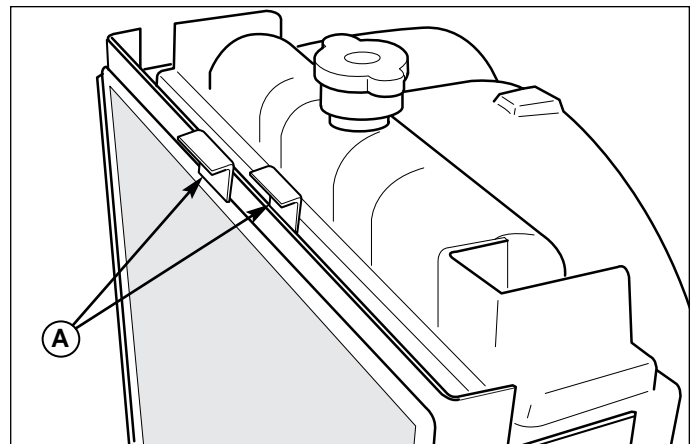
See engine owners manual for specific engine coolant procedures. The drain valve is located at the base of the right-hand side of the radiator.

## CLEAN RADIATOR & SCREENS

### (Gas Model)

Clean the radiator screens before each use to allow proper air-flow through radiator and engine compartment.

1. Open the hood
2. Slide both radiator screens (A, Figure 22) up and out of the mounting tracks.
3. Remove the radiator screens and flush with water or blow clean with air. Flush the radiator core with water or blow clean with air. See engine owners manual for proper radiator cleaning procedures.
4. Reinstall the screens.



**Figure 22. Radiator Screens**

- A. Radiator Screens

## CHECK WARNING LIGHTS AND ALARM

### (Both Models)

1. Turn the ignition key to the ON position, but DO NOT start the engine.
2. View the warning light gauge. The red lights containing each symbol for water temperature and oil pressure should be illuminated and the warning buzzer should also be on.

Once the engine is running, the buzzer and the warning lights should turn off. During operation, if the buzzer or warning lights come on, this indicates either high coolant temperature or low oil pressure.

If the lights are not visible, or the buzzer can not be heard, please contact your Ferris dealer.

# Regular Maintenance

## LUBRICATION

Lubricate the unit at the locations shown in Figure 23 through 29 as well as the following lubrication points.

### Grease:



- front caster wheel axles
- rear suspension a-arms
- rear deck mounts
- deck lift pivots
- deck lift foot pedal
- blade spindles

Use grease fittings when present. Disassemble parts to apply grease to moving parts when grease fittings are not installed.

Not all greases are compatible. Ferris Red Grease (P/N 22285) is recommended, automotive-type high-temperature, lithium grease may be used when this is not available.

### Oil:



- control handle pivots
- floor plate hinge
- discharge chute hinge

Generally, all moving metal parts should be oiled where contact is made with other parts. Keep oil and grease off belts and pulleys. Remember to wipe fittings and surfaces clean both before and after lubrication.

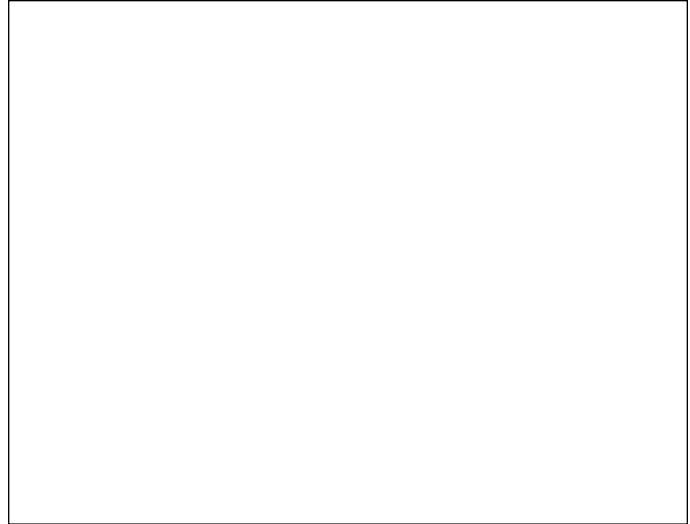


Figure 23. Deck Lift Pedal & Pivots

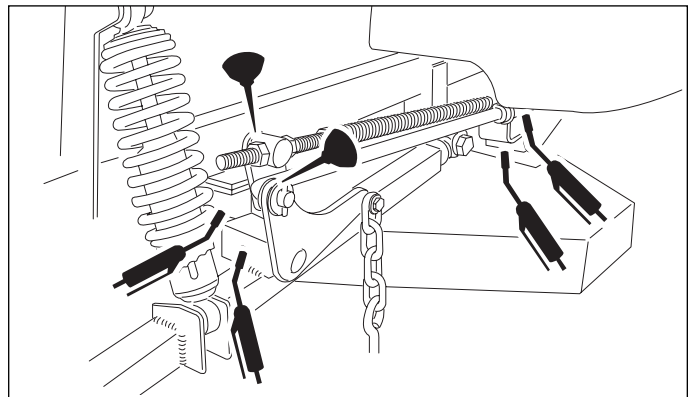


Figure 24. Deck Lift Linkage Pivots

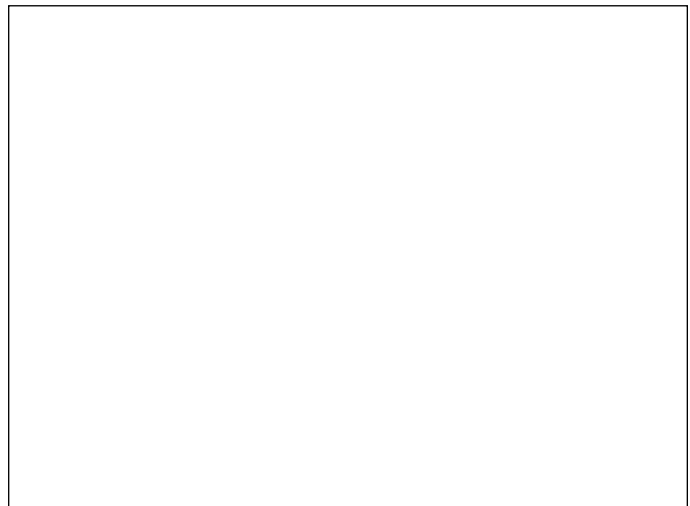
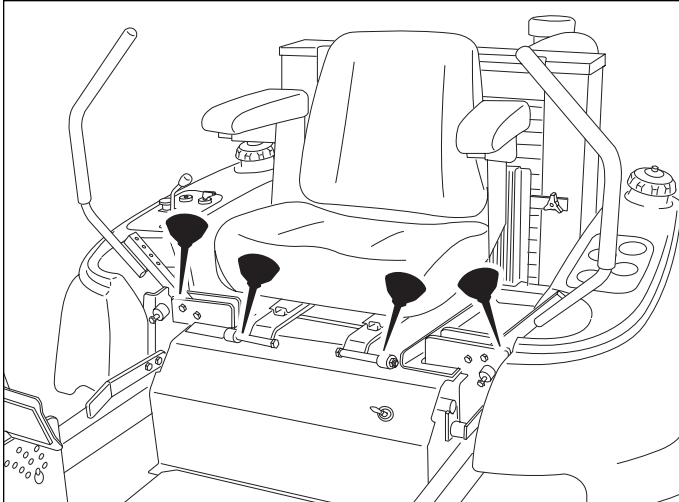
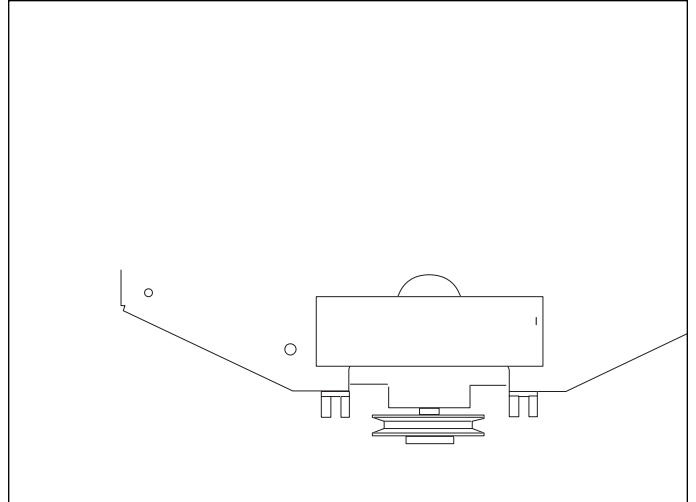


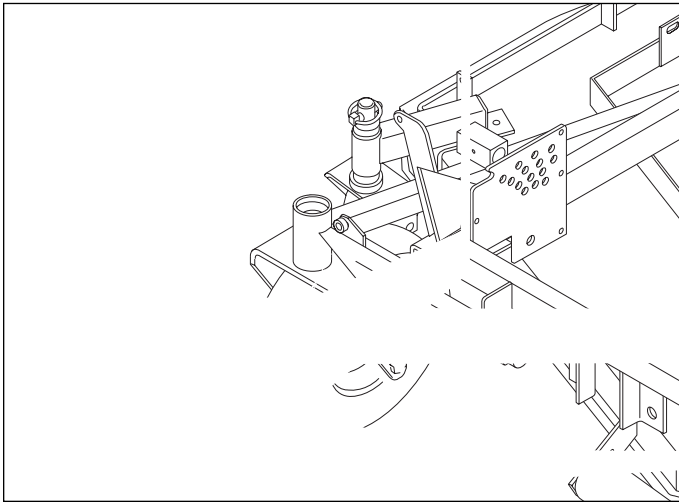
Figure 25. Deck Lubrication



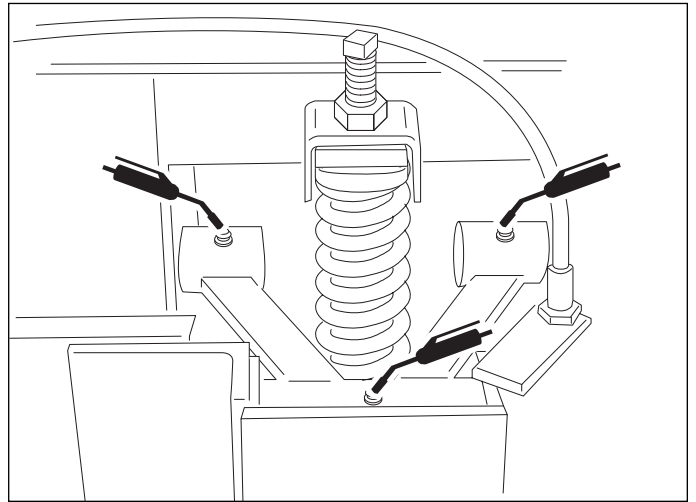
**Figure 26. Control Handle Pivots & Seat Pivots**



**Figure 27. Gearbox Drive Idler Pivot**



**Figure 28. Front Caster & Wheel**



**Figure 29. Rear Suspension Lubrication  
(Both upper & lower a-arms)**



## SERVICING THE MOWER BLADES

1. Blades should be sharp and free of nicks and dents. If not, sharpen blades as described in following steps.
2. To remove blade for sharpening, use a wood block to hold blade while using two 15/16" wrenches to removing the blade mounting bolt and nut (Figure 31).
3. Use a file to sharpen blade to fine edge. Remove all nicks and dents in blade edge. If blade is severely damaged, it should be replaced.
4. Balance the blade as shown in Figure 32. Center the blade's hole on a nail lubricated with a drop of oil. A balanced blade will remain level.
5. Reinstall each blade with the tabs pointing up toward deck as shown in Figure 33. The five (5) blade spacers, blade, washer and bolt must be reinstalled in the exact same order in which they were removed. Secure with a bolt and hex nut. Use a wooden block to prevent blade rotation and torque bolts to 70 ft.lbs. (94 N.m.).

### WARNING

Mower blades are sharp. For your personal safety, do not handle mower blades with bare hands. Careless or improper handling of blades may result in serious injury. For your personal safety, blade mounting bolts must each be installed with a flat washer then securely tightened. Torque blade mounting bolts to 70 ft.lbs. (94 N.m.)

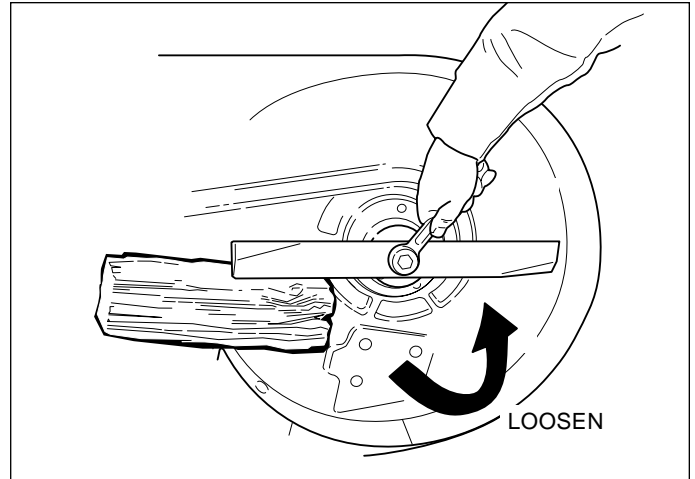


Figure 31. Removing the Blade

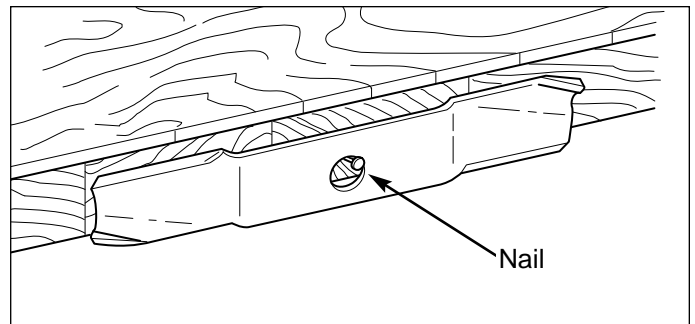


Figure 32. Balancing The Blade

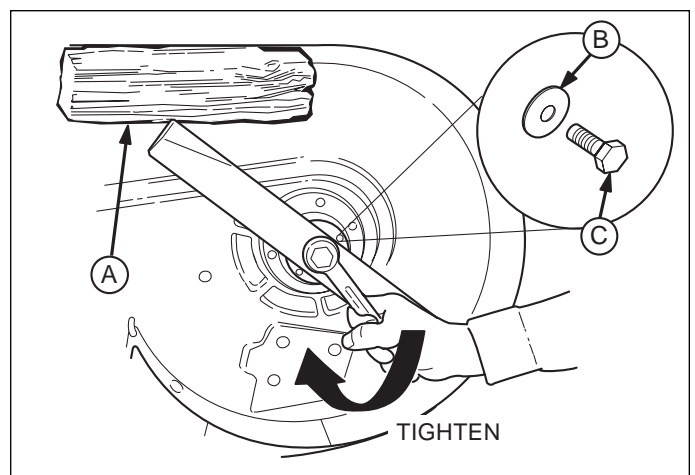
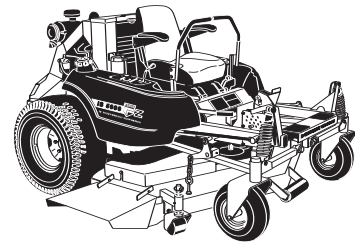


Figure 33. Installing The Blade

- A. 4x4 Wood Block    C. Blade Bolt  
B. Flat Washer

# Troubleshooting Adjustments & Service



## TROUBLESHOOTING

While normal care and regular maintenance will extend the life of your equipment, prolonged or constant use may eventually require that service be performed to allow it to continue operating properly.

The troubleshooting guide below lists the most common problems, their causes and remedies.

See the information on the following pages for instructions on how to perform most of these minor adjustments and service repairs yourself. If you prefer, all of these procedures can be performed for you by your local authorized dealer.

### **! WARNING**

**To avoid serious injury, perform maintenance on the tractor or mower only when the engine is stopped and the parking brake engaged.**

**Always remove the ignition key to prevent accidental starting of the engine.**

## TROUBLESHOOTING THE RIDER

PROBLEM	CAUSE	REMEDY
<b>Engine will not turnover or start.</b>	1. Parking brake not engaged.	1. Engage parking brake.
	2. PTO (electric clutch) switch in ON position.	2. Place in OFF position.
(Gas model)	3. Out of fuel.	3. If engine is hot, allow it to cool, then refill the fuel tanks.
(Diesel model)	4. Out of fuel.	3. If engine is hot, allow it to cool, then refill the fuel tanks. Prime the fuel system.
	5. Motion Control Handles not locked in neutral position.	4. Lock handles in neutral position.
	6. Operator not in seat.	5. Assume operator's position in seat.
(Diesel model)	7. Glow plugs not pre-heated.	6. Pre-heat glow plugs.
	8. Fuse blown.	7. Replace fuse.
(Gas model)	9. Engine flooded.	4. Move throttle control out of CHOKE position.
	10. Battery terminals require cleaning.	8. Clean the battery terminals
	11. Battery discharged or dead.	9. Recharge or replace.
(Gas model)	12. Spark plug(s) faulty, fouled or incorrectly gapped.	11. Clean and gap or replace. See engine manual.
	13. Wiring loose or broken.	10. Visually check wiring & replace broken or frayed wires. Tighten loose connections.
	14. Solenoid or starter motor faulty.	11. Repair or replace. See authorized service dealer
	15. Safety interlock switch faulty.	12. Replace as needed. See authorized service dealer.
	16. Water in fuel.	13. Drain fuel & refill with fresh fuel.
	17. Fuel is old or stale.	14. Drain fuel & replace with fresh fuel.
<b>Engine starts hard or runs poorly.</b>	1. Fuel mixture too rich.	1. Clean air filter.
(Diesel model)	2. Air in fuel system.	2. Prime the fuel system.
(Gas model)	3. Spark plug faulty, fouled, or incorrectly gapped.	2. Clean and gap or replace. (See engine manual.)
<b>Engine knocks.</b>	1. Low oil level.	1. Check/add oil as required.
	2. Using wrong grade oil.	2. See engine manual.
<b>Excessive oil consumption.</b>	1. Engine running too hot.	1. Clean radiator screens and air cleaner.
	2. Using wrong weight oil.	2. See engine manual.
	3. Too much oil in crankcase.	3. Drain excess oil.
<b>Engine exhaust is black.</b>	1. Dirty air filter.	1. Replace air filter. See engine manual.
(Diesel model)	2. Air in fuel system	2. Prime the fuel system.
(Gas model)	3. Engine choke control is in closed position.	2. Open choke control.



## ***Rider Troubleshooting Continued.***

<b>PROBLEM</b>	<b>CAUSE</b>	<b>REMEDY</b>
<b>Engine runs, but rider will not drive.</b>	<ol style="list-style-type: none"> <li>1. Hydraulic dump valve(s) in "open" position.</li> <li>2. Belt is broken.</li> <li>3. Drive belt slips.</li> <li>4. Brake is not fully released.</li> </ol>	<ol style="list-style-type: none"> <li>1. Turn dump valve(s) clockwise to close. Torque to 80-120 in.lbs. (9-13.5 N.m.)</li> <li>2. See Drive Belt Replacement.</li> <li>3. See problem and cause below.</li> <li>4. See authorized service dealer</li> </ol>
<b>Hydraulic pump drive belt slips.</b>	<ol style="list-style-type: none"> <li>1. Pulleys or belt greasy or oily.</li> <li>2. Belt stretched or worn.</li> </ol>	<ol style="list-style-type: none"> <li>1. Clean as required.</li> <li>2. Replace belt.</li> </ol>
<b>Brake will not hold.</b>	<ol style="list-style-type: none"> <li>1. Brake is incorrectly adjusted.</li> <li>2. Brake caliper pads worn.</li> </ol>	<ol style="list-style-type: none"> <li>1. See Brake Adjustment.</li> <li>2. Replace with new brake pads.</li> </ol>
<b>Rider steers or handles poorly.</b>	<ol style="list-style-type: none"> <li>1. Steering linkage is loose.</li> <li>2. Improper tire inflation.</li> </ol>	<ol style="list-style-type: none"> <li>1. Check and tighten any loose connections.</li> <li>2. See Regular Maintenance Section.</li> </ol>

## **TROUBLESHOOTING THE MOWER**

<b>PROBLEM</b>	<b>CAUSE</b>	<b>REMEDY</b>
<b>Mower will not raise.</b>	<ol style="list-style-type: none"> <li>1. Lift linkage not properly attached or damaged.</li> </ol>	<ol style="list-style-type: none"> <li>1. See authorized service dealer for repair.</li> </ol>
<b>Mower cut is uneven.</b>	<ol style="list-style-type: none"> <li>1. Mower not leveled properly.</li> <li>2. Rider tires not inflated equally or properly.</li> </ol>	<ol style="list-style-type: none"> <li>1. See Mower Adjustment.</li> <li>2. See Regular Maintenance Section.</li> </ol>
<b>Mower cut is rough looking.</b>	<ol style="list-style-type: none"> <li>1. Engine speed too slow.</li> <li>2. Ground speed too fast.</li> <li>3. Blades are dull.</li> <li>4. Mower drive belt slipping because it is oily or worn.</li> <li>5. Blades not properly fastened to spindles.</li> </ol>	<ol style="list-style-type: none"> <li>1. Set throttle to full.</li> <li>2. Decrease Ground Speed.</li> <li>3. Sharpen or replace blades. See Mower Blade Service.</li> <li>4. Clean or replace belt as necessary.</li> <li>5. See Servicing the Mower Blades.</li> </ol>
<b>Engine stalls easily with mower engaged.</b>	<ol style="list-style-type: none"> <li>1. Engine speed too slow.</li> <li>2. Ground speed too fast.</li> <li>3. Cutting height set too low.</li> <li>4. Discharge chute jamming with cut grass.</li> </ol>	<ol style="list-style-type: none"> <li>1. Set to full throttle.</li> <li>2. Decrease Ground Speed.</li> <li>3. Cut tall grass at maximum cutting height during first pass.</li> <li>4. Cut grass with discharge pointing toward previously cut area.</li> </ol>
<b>Excessive mower vibration.</b>	<ol style="list-style-type: none"> <li>1. Blade mounting bolts are loose.</li> <li>2. Mower blades, spindles, or pulleys are bent.</li> <li>3. Mower blades are out of balance.</li> <li>4. Belt installed incorrectly.</li> </ol>	<ol style="list-style-type: none"> <li>1. Tighten to 70 ft.lbs. (94 N.m.).</li> <li>2. Check and replace as necessary.</li> <li>3. Remove, sharpen, and balance blades. See Maintenance Section.</li> <li>4. Reinstall Correctly.</li> </ol>
<b>Excessive belt wear or breakage.</b>	<ol style="list-style-type: none"> <li>1. Bent or rough pulleys.</li> <li>2. Using incorrect belt.</li> </ol>	<ol style="list-style-type: none"> <li>1. Repair or replace.</li> <li>2. Replace with correct belt.</li> </ol>
<b>Mower drive belt slips or fails to drive.</b>	<ol style="list-style-type: none"> <li>1. Idler pulley spring broken or not properly attached.</li> <li>2. Mower drive belt broken.</li> </ol>	<ol style="list-style-type: none"> <li>1. Repair or replace as needed.</li> <li>2. Replace drive belt.</li> </ol>

# Troubleshooting, Adjustment & Service

## SEAT ADJUSTMENT

See Figure 34. The seat can be adjusted fore and aft. Move the lever forward, position the seat as desired, and release the lever to lock the seat into position.

## GROUND SPEED CONTROL LEVER ADJUSTMENT

The control levers can be adjusted in three ways. The alignment of the control levers, the placement of the levers (how close the ends are to one another) and the height of the levers can be adjusted.

### Handle Alignment

Loosen the mount hardware (A, Figure 35) and pivot the lever(s) (C, Figure 35) fore or aft to align with each other.

### Handle Placement

Loosen the jam nuts and adjust the placement bolt (B, Figure 35) in or out to properly adjust the lever end spacing.

### Handle Height

Remove the mounting hardware (A, Figure 35) and reposition the handle either up or down from its original position. You will need to readjust the handle alignment as described above.

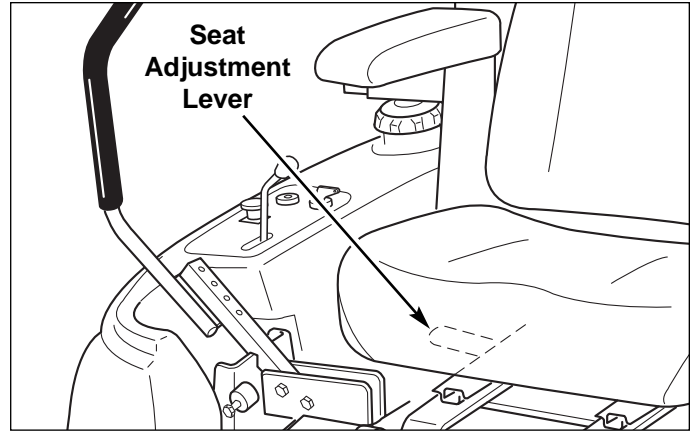


Figure 34. Seat Adjustment

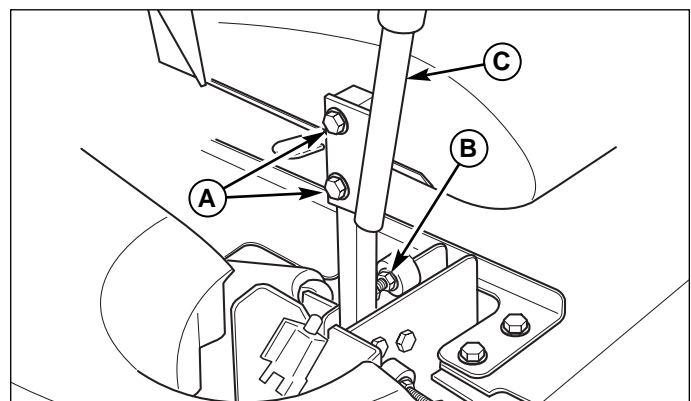


Figure 35. Control Lever Adjustment

- A. Alignment Hardware
- B. Placement Hardware
- C. Ground Speed Control Lever

## SPEED BALANCING ADJUSTMENT

If the rider veers to the right or left when the ground speed control levers are in the maximum forward position, the top speed of each of these levers can be balanced by turning the adjustment bolt(s) (A, Figure 36). Only adjust the speed of the wheel that is traveling faster.

### To Reduce the Speed of the Faster Wheel

1. Loosen the securing nut.
2. turn the top speed adjustment bolt CLOCKWISE to reduce the speed.
3. Retighten the securing nut when adjustment is complete.

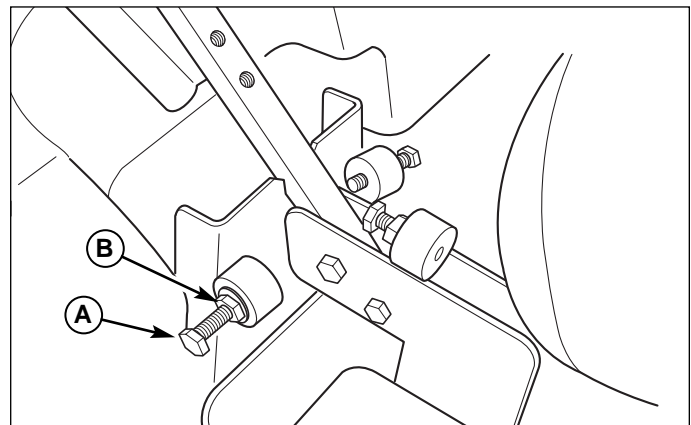


Figure 36. Top Speed Adjustment

- A. Top Speed Adjustment Screw
- B. Jam Nut

## **!** WARNING

**DO NOT** adjust the tractor for a faster overall speed forward or reverse than it was designed for.

## NEUTRAL ADJUSTMENT

If the tractor “creeps” while the ground speed control levers are locked in NEUTRAL, then it may be necessary to adjust the control linkage.

*NOTE: Perform this adjustment on a hard, level surface such as a concrete floor.*

1. Disengage the PTO, engage the parking brake and turn off the engine.
2. Loosen the jam nuts (B, Figure 37) and turn the adjustment linkage (A, Figure 37) to adjust. If the machine creeps forward, turn the linkage CLOCKWISE (while standing at the rear of the machine, facing forward), if the machine creeps backward, turn the linkage COUNTER-CLOCKWISE.
3. Lock the jam nuts (B) when neutral is achieved.

*NOTE: This adjustment should not be performed while the machine is running. It may take several attempts to achieve neutral, depending upon how much the machine creeps.*

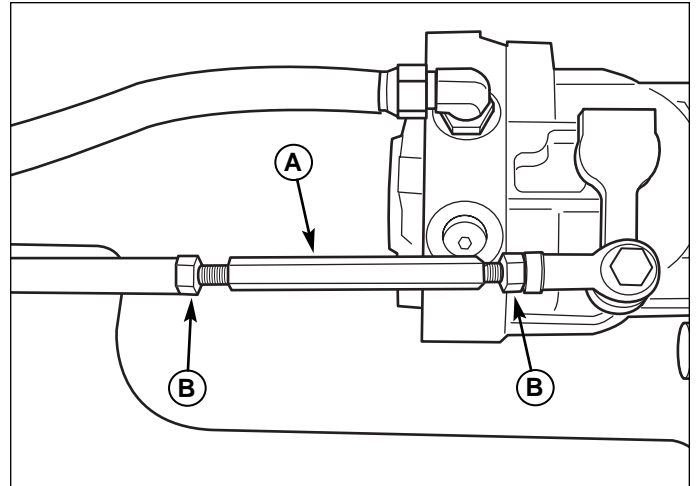
## NEUTRAL POSITION AND RETURN SPRING ADJUSTMENT

To determine if it is necessary to adjust the neutral position, perform the following steps.

1. Disengage the PTO, engage the parking brake and turn off the engine.
2. Move the ground speed control levers in the operating position, pull levers rearward and release.
3. Move the ground speed control levers towards the neutral position. If the levers do not align with the notches in the neutral lock plate, it is necessary to adjust the reverse return bolts (A, Figure 38).

### Neutral Position Adjustment

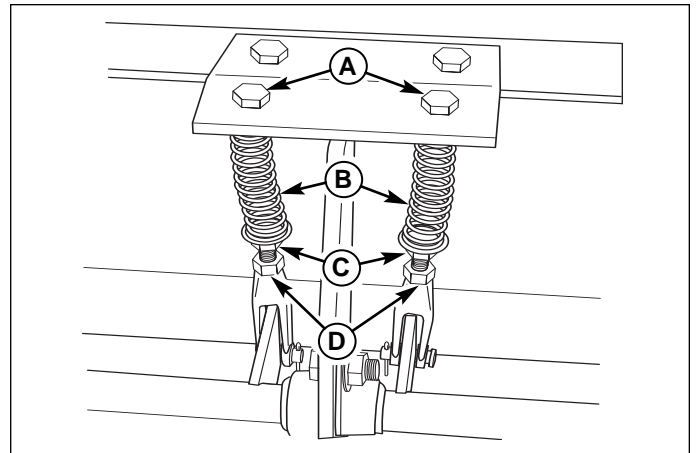
1. Loosen the jam nut (D, Figure 38) locked against the clevis.
2. Turn the reverse return bolt (A, Figure 38) clockwise to adjust handle rearward, counter-clockwise to adjust handle forward.
4. Pull lever rearward and release to check position again. Adjust as necessary to align levers with notches.
5. Once the lever alignment has been adjusted, lock jam nut against the clevis.



**Figure 37. Neutral Adjustment**

(Left-hand side shown)

- A. Control Linkage
- B. Jam Nuts



**Figure 38. Neutral Spring Return Adjustment**

- A. Reverse Return Bolt
- B. Reverse Return Spring
- C. Spring Position Nut
- D. Jam Nut

### Return Spring Adjustment

After adjusting the neutral position, lock the levers in the neutral position and measure the reverse return spring (B, Figure 38) length. This should be 2-3/8” long. If not, hold the reverse return bolt (A, Figure 38) with a wrench while turning the spring position nut (C, Figure 38) until the measurement is achieved.

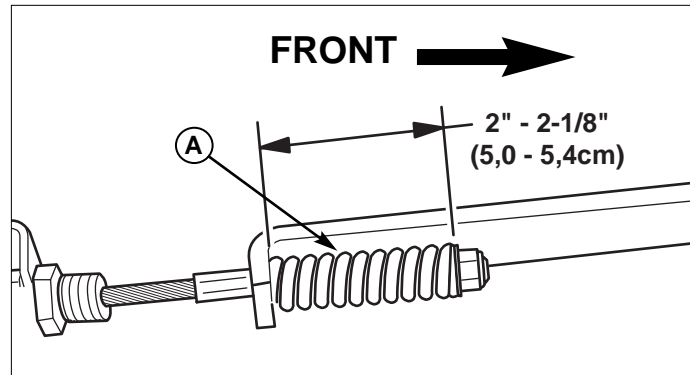
## PARKING BRAKE ADJUSTMENT

1. Disengage the PTO, stop the engine, block the front wheels, remove the ignition key, and engage the parking brake.
2. Locate the upper brake spring (A, Figure 39).
3. With the parking brake engaged, measure the compressed spring length. The spring should be 2" to 2-1/8" (5,0-5,4cm) when compressed.
4. If the spring is not within this range, jack up the rear of the machine and secure with jackstands. Remove both drive tires.
5. Locate the lower brake spring (A, Figure 40), adjustment nuts (B, Figure 40) and adjustment link (C, Figure 40).
6. Release the parking brake and turn the adjustment nuts to compress or release the upper spring. Lock the nuts against the adjustment link (C, Figure 40).

### **CAUTION**

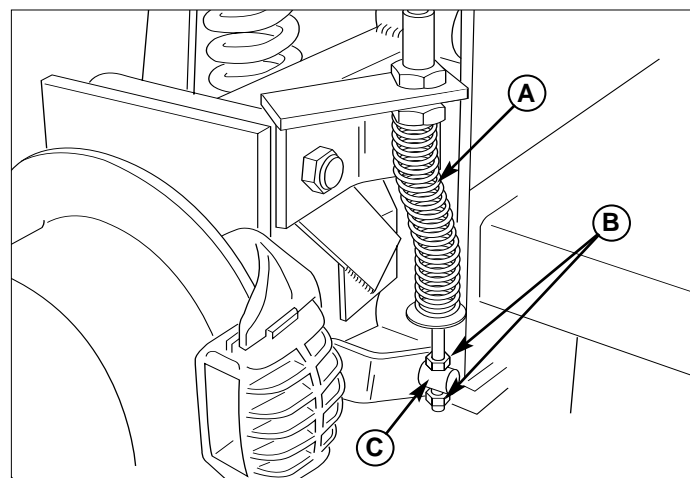
Do not adjust the spring to be shorter than 2" (5,0cm) when compressed. This may damage the brake caliper.

If this does not correct the braking problem, see your dealer.



**Figure 39. Parking Brake Adjustment**

A. Upper Brake Spring



**Figure 40. Parking Brake Adjustment**

A. Lower Brake Spring

B. Adjustment Nuts

C. Adjustment Link

### FRONT SUSPENSION ADJUSTMENT

The shock assembly can be adjusted to vary the amount of pre-load applied to the springs. This allows the operator to customize the ride according to operator's weight and/or operating conditions.

#### Less Pre-Load:

- Light operator weight
- Softer, more cushioned ride
- Best for relatively flat terrain

#### More Pre-Load:

- Heavy operator weight
- Stiffer, more rigid ride
- Better handling and greater stability on hilly terrain

#### To adjust the spring pre-load:

1. Park machine on a flat, level surface. Disengage the PTO, stop the engine and engage the parking brake.
2. See Figure 41. Using the supplied spanner wrench (p/n 22853), insert the tip of the wrench into the notch in the pre-load adjuster. While holding the wrench in place with one hand, turn **CLOCKWISE** to increase the pre-load, turn **COUNTER-CLOCKWISE** to decrease the pre-load. Make sure both shocks are set to the same amount of pre-load.

*NOTE: Spanner wrench is located under the seat, in front of the oil reservoir and alarm.*

### REAR SUSPENSION ADJUSTMENT

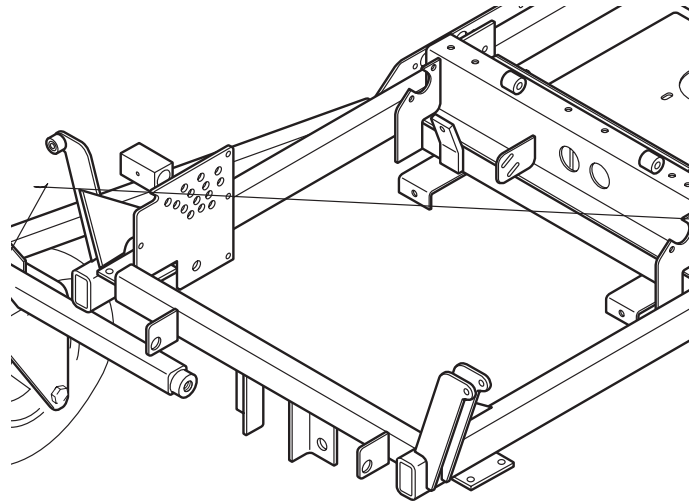
If the rider tilts side-to-side, this adjustment will level the frame with the ground.

Although this adjustment may not be necessary, it may be required if additional weight (ie. a grass catcher) is added to the frame or a drive tire is replaced.

*NOTE: Perform this adjustment on a hard, level surface such as a concrete floor.*

#### To level the frame, first measure the frame height:

1. The measurement to the top of the rear frame rails, at the widest point on the frame behind the drive tires should be 22-3/8" (56,8cm) for each side (see arrow in Figure 42).
3. Loosen the jam nuts and adjust the square-head allen screw located above each spring.
4. After adjusting both springs, recheck the measurement and adjust if necessary.



# Troubleshooting, Adjustment & Service

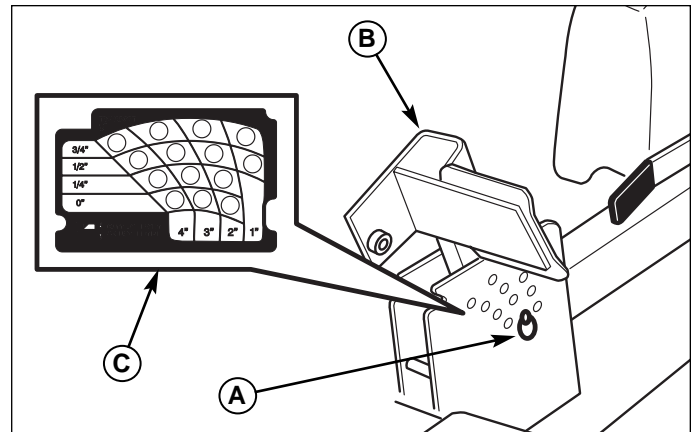
## MOWING HEIGHT ADJUSTMENT

See Deck Leveling Adjustment to ensure that the actual cutting height is consistent with the cutting height adjustment pin placement.

The cutting height adjustment pin (A, Figure 43) controls the mower cutting height. The cutting height is adjustable between 1-1/2" (3,8cm) and 5" (12,7cm) in 1/4" (0,64cm) increments.

Depress the deck lift foot pedal (B, Figure 43), placing the majority of the force on the top edge of the pedal until it locks into the "TRANSPORT" position.

Place the cutting height adjustment pin in the desired cutting height. Depress the deck lift foot pedal, placing the majority of the force on the bottom edge of the pedal to release the pedal from the "TRANSPORT" position.

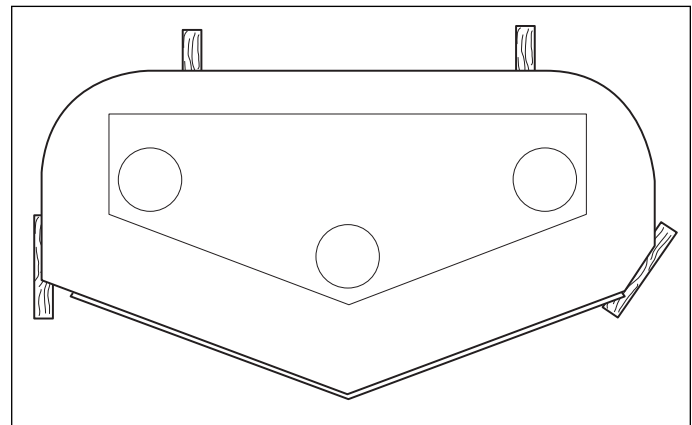


**Figure 43. Mowing Height Adjustment**

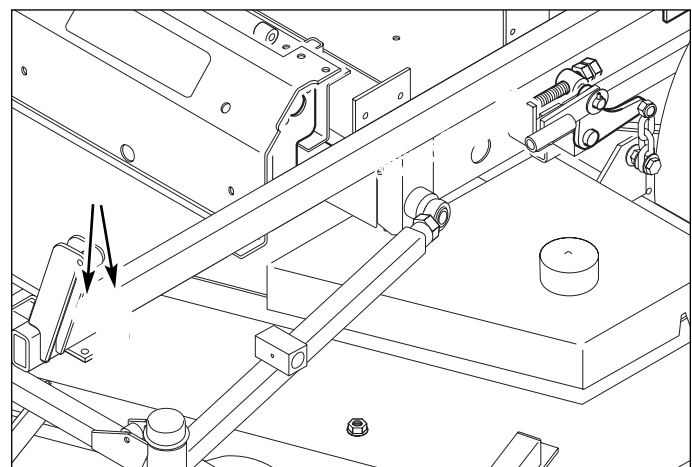
- A. Cutting Height Adjustment Pin
- B. Deck Lift Foot Pedal
- C. Cutting Height Selection Decal

## DECK LEVELING ADJUSTMENT

1. Park machine on a flat, level surface. Disengage the PTO, stop the engine and engage the parking brake. Rear tires must be inflated to 18 psi (124 kPa); front tires to 25 psi (172 kPa).
2. Lock the deck lift pedal in the TRANSPORT position. Place the deck height adjustment pin in the 4" position and lower deck the lift pedal until the arm contacts the pin.
3. Place 2 x 4 blocks under each corner of the mower deck with the 3-1/2" sides being vertical. Place a 1/4" (0,64cm) thick spacer on top of the rear 2 x 4 blocks. See Figure 44.
4. See Figure 45. Measure the distance between the lift pivots and the spring rod pivots. Adjust the 5/8" hex nuts on either side of the front spring rod pivot until the measurements are equal.

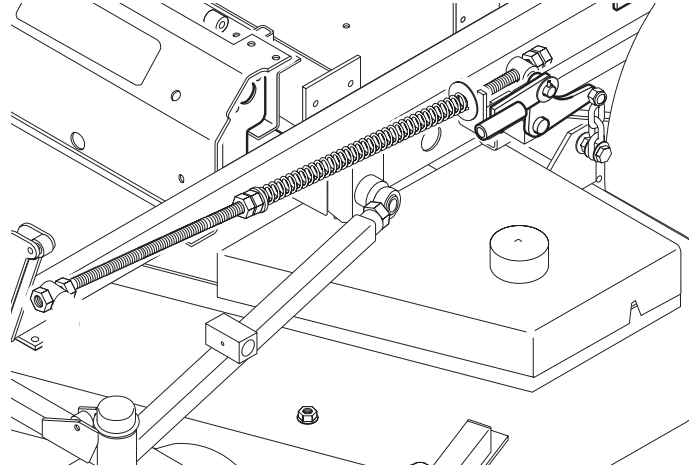


**Figure 44. 2 x 4 Locations**



**Figure 45. Spring Rod Adjustment**

5. See Figure 46. Measure the distance between the rear lift pivots and the suspension-mounted lift pivots. Add or remove  $5/8$ " SAE washers from in between the deck lift rod and the lift link until measurements are equal.



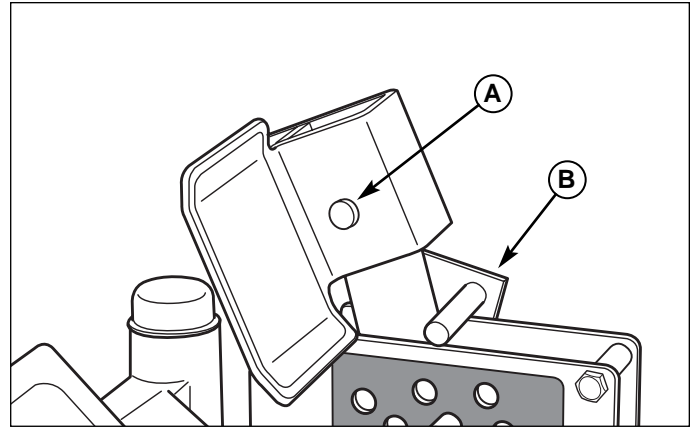
## BELT REMOVAL & REPLACEMENT



To avoid damaging belts, **DO NOT PRY BELTS OVER PULLEYS.**

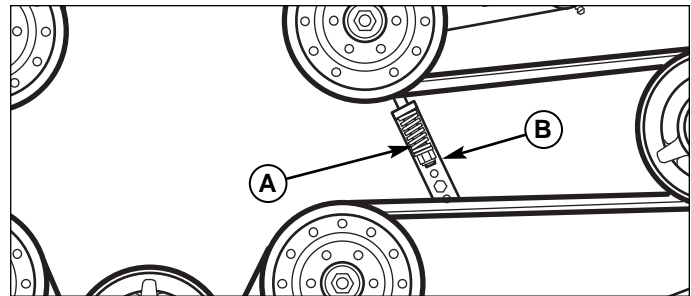
### Mower Drive Belt Removal & Replacement

1. Park the tractor on a smooth, level surface such as a concrete floor. Disengage the PTO, engage the parking brake, turn off the engine, and remove the ignition key.
2. See Figure 48. Remove the hairpin clip and clevis pin and remove the deck lift foot pedal. Lift the floor plate to gain access to the PTO drive belt.
3. Remove the mower deck guards.
4. Loosen the spring compression nut (B, Figure 49) to release the belt tension.
5. Slide the drive belt over the edge of the spring-loaded idler pulley and remove belt from all pulley grooves.
6. Remove the old belt and replace with a new one. Make sure the V-side of the belt runs in the pulley grooves (Figure 50).
7. Install the drive belt on the gearbox pulley, the spindle pulleys and idler pulleys. Tighten the spring compression nut (B, Figure 49) until the belt tension spring (A, Figure 49) is compressed to 1-5/8" (4,12cm) long.
8. Lower the floor pan and reinstall the deck lift foot pedal, clevis pin and hairpin clip. Make sure the deck lift lock bar is located as shown in Figure 48.
9. Reinstall the mower deck guards and secure with the 5/16" hardware previously removed.
10. Run the mower under no-load condition for approximately 5 minutes to break in the belt.



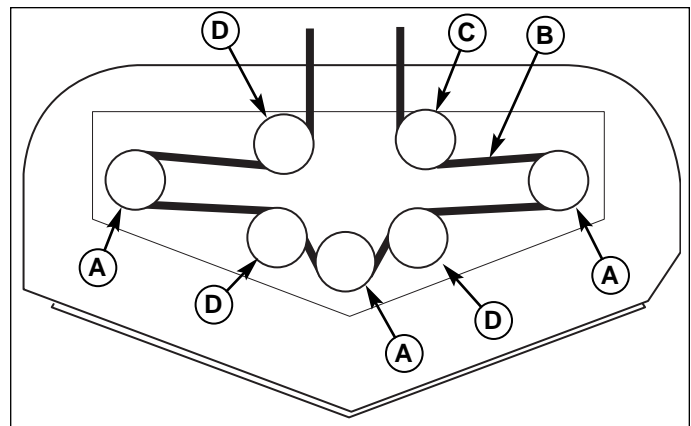
**Figure 48. Remove Lift Pedal**

- A. Clevis Pin
- B. Deck Lift Lock Bar



**Figure 49. Mower PTO Belt**

- A. Belt Tension Spring
- B. Spring Compression Nut



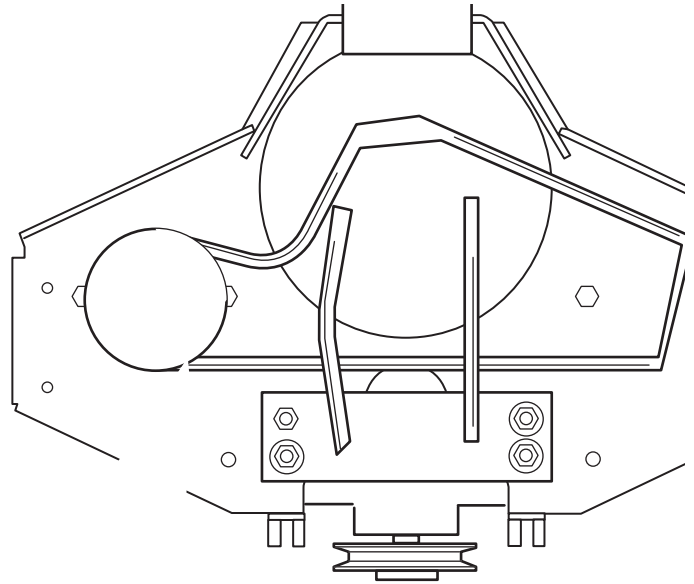
**Figure 50. Mower PTO Belt Routing**

- A. Spindle Pulley
- B. PTO Drive Belt
- C. Spring-loaded Idler Pulley
- D. Stationary Idler Pulley



## Clutch Belt Removal

1. Park the tractor on a smooth, level surface such as a concrete floor. Disengage the PTO, engage the parking brake, turn off the engine, and remove the ignition key.
2. Remove the rear skid plate by removing the bolts that fasten the skid plate to the bumper and slide the plate forward until it drops from the mounts.
3. Remove the rear belt shield and rear hood support.
4. Remove the bumper.
5. Remove the nylon lock nut (A, Figure 51) to release the belt tension and unhook the clutch belt idler spring (C) from the screw hook (B). Set the screw hook aside.
6. Remove the 5/16" bolt, washer and nut (D) that fasten the rubber pad to the clutch and unscrew the wire ends that connect the clutch to the electrical harness.
7. Pulling the belts over the bottom edge of the gearbox drive pulley (E), remove the clutch belts from the clutch pulley grooves and pull around the idler pulley



## Clutch Belt Replacement & Adjustment

1. Install the clutch belts over the top of the clutch pulley into the grooves of the crankshaft pulley and around the idler pulley.
2. Push the belts over the edge of the gearbox drive pulley and into the grooves of the pulley.

Hook the clutch belt idler spring or screw hook and reinstall the screw hook into the hook. Adjust the screw hook until the spring is 1 cm (0.4 in) to the outside of the loops on the

rubber pad to the clutch with the electrical harness removed. Make sure the electrical harness is in the same order as is was before being

removed. Reinstall the bumper, rear hood support, rear belt shield, and rear skid plate.

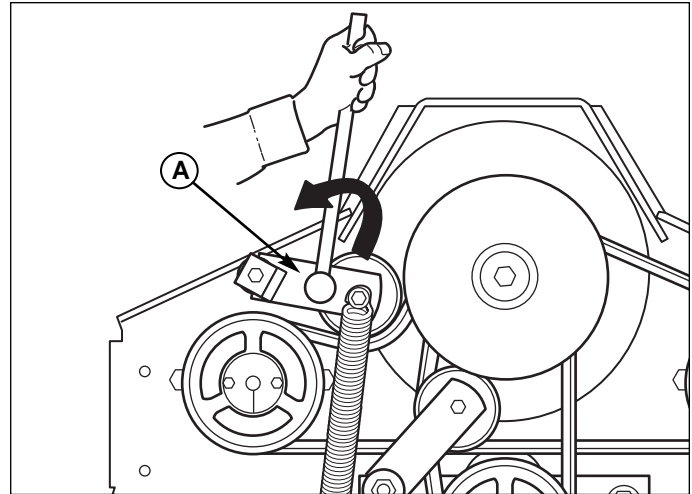
# Troubleshooting, Adjustment & Service

## Pump Drive Belt Removal

1. Park the tractor on a smooth, level surface such as a concrete floor. Disengage the PTO, engage the parking brake, turn off the engine, and remove the ignition key.
2. Remove the clutch belts (see *CLUTCH BELT REMOVAL* for instructions).
3. Using a 1/2" breaker bar, place the square end in the square hole located in the middle of the idler arm (A, Figures 53). Carefully rotate the breaker bar counter-clockwise, which will relieve the tension on the belts exerted from the idler arm.

### **! WARNING**

**Use extreme caution when rotating the idler arm with the breaker bar, due to the increased tension in the spring as the idler arm is being rotated. Injury may result if the breaker bar is prematurely released while the spring is under tension.**



**Figure 53. Pump Belt Removal & Replacement**  
A. Pump Drive Idler Arm

4. Remove the belts from the right-hand and left-hand pump drive pulley grooves.
5. Carefully release the tension on the breaker bar until the idler arm stops against the left-hand pump drive pulley.
6. Remove the belts from the crankshaft pulley grooves and pull over the top of the clutch.

## Pump Drive Belt Replacement

1. Place the belts over the clutch into the crankshaft pulley grooves.
2. Carefully rotate the idler arm with the breaker bar counter-clockwise (see Figure 53) and wrap the belts around the bottom side of the idler arm pulley and place the belts in the left-hand pump pulley grooves.
4. While holding the breaker bar firmly, place the belts in the right-hand pump pulley grooves.
5. Carefully release the tension on the breaker bar.
6. Inspect the belt path making sure that all belts are properly seated in the pulley grooves.
7. Reinstall the clutch belts (see *CLUTCH BELT REPLACEMENT & ADJUSTMENT* for instructions).

## GEARBOX MAINTENANCE

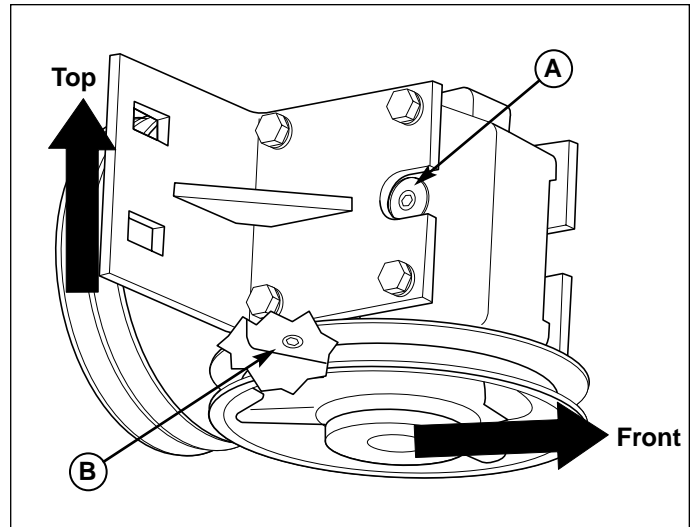
### Check Gearbox Oil Level

1. Remove fill plug (A, Figure 54) on gearbox.
2. Once plug is removed, oil should seep out of fill plug hole. If no oil drains out, fill with SAE 80-90 weight gear oil until oil starts to seep from hole, then replace fill plug.

### Changing Gearbox Oil

*NOTE: The gearbox lubricant should be changed after the first 100 hrs. or 30 days of operation, then after 500 hours or 12 months.*

1. Remove the mower deck drive belt (see *MOWER DRIVE BELT REMOVAL & REPLACEMENT* for instructions).
2. Rotate the the mower deck drive pulley on the gearbox so the drain plug is aligned with the opening between the pulley spokes.
3. Place a container under the gearbox drain hole and remove the drain plug (B).
4. Replace drain plug and fill with SAE 80-90 weight gear oil until oil starts to seep from hole, then replace fill plug.
5. Using a parts solvent, thoroughly clean any excess oil from the pulley faces and groove.
6. Reinstall the mower deck drive belt (see *MOWER DRIVE BELT REMOVAL & REPLACEMENT* for instructions).



**Figure 54. Gearbox Oil Level**

- A. Fill Plug
- B. Drain Plug

## BATTERY SERVICE

### **WARNING**

Keep open flames and sparks away from the battery; the gasses coming from it are highly explosive. Ventilate the battery well during charging.

### Checking Battery Voltage

A voltmeter can be used to determine condition of battery. When engine is off, the voltmeter shows battery voltage, which should be 12 volts. When engine is running, the voltmeter shows voltage of charging circuit which normally is 13 to 14 volts.

A dead battery or one too weak to start the engine may not mean the battery needs to be replaced. For example, it may mean that the alternator is not charging the battery properly. If there is any doubt about the cause of the problem, see your dealer. If you need to replace the battery, follow the steps under Cleaning the Battery & Cables in the Regular Maintenance Section.

## CHARGING A COMPLETELY DISCHARGED BATTERY

1. Be aware of all the safety precautions you should observe during the charging operation. If you are unfamiliar with the use of a battery charger and hydrometer, have the battery serviced by your dealer.
2. Add distilled water sufficient to cover the plate (fill to the proper level near the end of the charge). If the battery is extremely cold, allow it to warm before adding water because the water level will rise as it warms. Also, an extremely cold battery will not accept a normal charge until it becomes warm.
3. Always unplug or turn the charger off before attaching or removing the clamp connections.
4. Carefully attach the clamps to the battery in proper polarity (usually red to [+] positive and black to [-] negative).
5. While charging, periodically measure the temperature of the electrolyte. If the temperature exceeds 125° F (51.6° C), or if violent gassing or spewing of electrolyte occurs, the charging rate must be reduced or temporarily halted to prevent battery damage.

6. Charge the battery until fully charged (until the specific gravity of the electrolyte is 1.250 or higher and the electrolyte temperature is at least 60° F). The best method of making certain a battery is fully charged, but not over charged, is to measure the specific gravity of a cell once per hour. The battery is fully charged when the cells are gassing freely at low charging rate and less than 0.003 change in specific gravity occurs over a three hour period.

## JUMP STARTING WITH AUXILIARY (BOOSTER) BATTERY

Jump starting is not recommended. However, if it must be done, follow these directions. Both booster and discharged batteries should be treated carefully when using jumper cables. Follow the steps below EXACTLY, being careful not to cause sparks. Refer to Figure 55.

1. Both batteries must be of the same voltage.
2. Position the vehicle with the booster battery adjacent to the vehicle with the discharged battery so that booster cables can be connected easily to the batteries in both vehicles. Make certain vehicles do not touch each other.
3. Wear safety glasses and shield eyes and face from batteries at all times. Be sure vent caps are tight. Place damp cloth over vent caps on both batteries.
4. Connect positive (+) cable to positive post of discharged battery (wired to starter or solenoid).
5. Connect the other end of same cable to same post marked positive (+) on booster battery.
6. Connect the second cable negative (-) to other post of booster battery.
7. Make final connection on engine block of stalled vehicle away from battery. Do not lean over batteries.
8. Start the engine of the vehicle with the booster battery. Wait a few minutes, then attempt to start the engine of the vehicle with the discharged battery.
9. If the vehicle does not start after cranking for thirty seconds, STOP PROCEDURE. More than thirty seconds seldom starts the engine unless some mechanical adjustment is made.
10. After starting, allow the engine to return to idle speed. Remove the cable connection at the engine or frame. Then remove the other end of the same cable from the booster battery.
11. Remove the other cable by disconnecting at the discharged battery first and then disconnect the opposite end from the booster battery.
12. Discard the damp cloths that were placed over the battery vent caps.

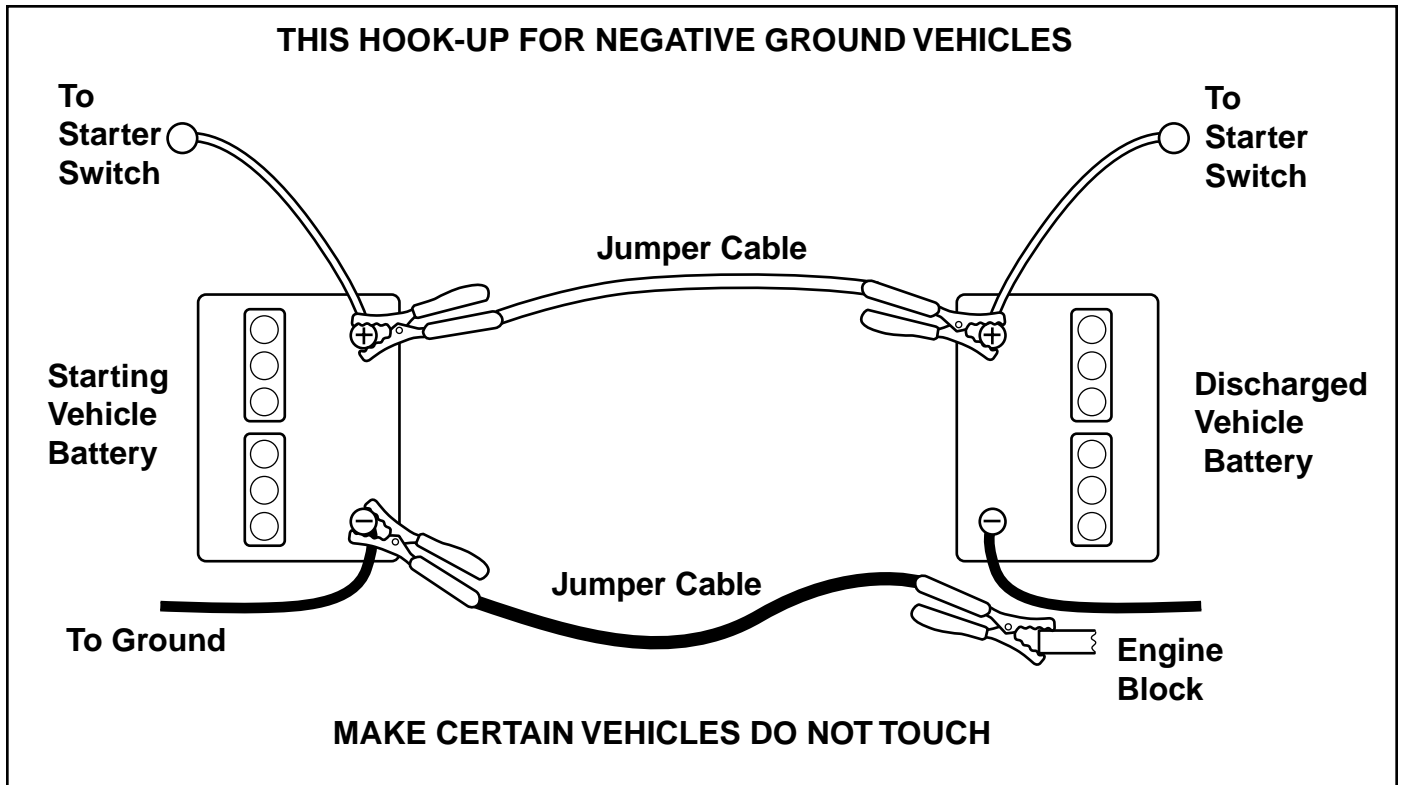


Figure 55. Jump Starting

## **⚠ WARNING**

Any procedure other than the preceding could result in:

- (1) personal injury caused by electrolyte squirting out the battery vents,
- (2) personal injury or property damage due to battery explosion,
- (3) damage to the charging system of the booster vehicle or of the immobilized vehicle.

Do not attempt to jump start a vehicle having a frozen battery because the battery may rupture or explode. If a frozen battery is suspected, examine all fill vents on the battery. If ice can be seen or if the electrolyte fluid cannot be seen, do not attempt to start with jumper cables as long as the battery remains frozen.

## **⚠ WARNING**

For your personal safety, use extreme care when jump starting. Never expose battery to open flame or electric spark – battery action generates hydrogen gas which is flammable and explosive. Do not allow battery acid to contact skin, eyes, fabrics, or painted surfaces. Batteries contain a sulfuric acid solution which can cause serious personal injury or property damage.

When removing or installing battery cables, disconnect the negative cable **FIRST** and reconnect it **LAST**. If not done in this order, the positive terminal can be shorted to the frame by a tool.

To avoid engine damage, do not disconnect battery while engine is running. Be sure terminal connections are tight before starting.

# Common Replacement Parts

---

## COMMON REPLACEMENT PARTS

Listed below are parts numbers for the more common replacement parts. Use only genuine Ferris replacement parts to assure optimum performance and safety.

**72" Deck Belt** (Gearbox to Spindle) .....22439

**72" Deck Blades** (Set of 3) .....22476S

**Gearbox Drive Belt** (PTO to Gearbox) .....22575

**Pump Drive Belt**.....22314

**Deck Caster Roller** .....22060

**Deck Nose Roller**.....20785

**Touch-Up Spray Paint** (12 oz can) .....22585

(Ferris Red)

**Ferris Red Grease** (14.5 oz. Tube) .....22285

**Spanner Wrench** (for front shocks) .....22853

**Hydraulic Oil Filter** .....21357

**Foam Grip** (Motion Control Handles) .....22068

**Foam Grip** (Brake Handle) .....25510

**20A Fuse** .....21603

**30A Fuse** .....21771

### DIESEL MODEL ONLY

**Air Cleaner Element** .....22883-31

**Engine Oil Filter**.....22883-11

**Fuel Filter** (200 hr.) .....22883-19A

**Fuel Filter Assembly** (500 hr.) .....22883-19B

**Fuel Filter Element** (500 hr.).....22883-19C

**Water Separator Element**.....22926-1

**60A Fuse** .....22911

*Note: Information listed above is correct at time of printing, and are subject to changes in availability and specifications without notice. Part numbers may be superceded by other part numbers.*



## GENERAL INFORMATION

Proper mowing is an important part of maintaining your lawn in the best possible condition. A healthy and well maintained lawn is better able to resist drought, weeds, and other stresses. But too much maintenance is as detrimental to your lawn as neglect. Proper care for your lawn involves more than just “cutting the grass.” To have a healthy lawn, you need to know:

- Types of Grass, Climate and Conditions
- How and When to Water, Fertilize & Aerate
- How High to Mow the Grass
- When and How Often to Mow
- What Mowing Patterns to Use
- Proper Mowing Methods
- How to Solve Common Mowing Problems

A variety of grasses are commonly grown in household lawns, but two main groups known as cool-season grasses (varieties of bluegrass, ryegrass, and fescue), and warm-season grasses (typically bermuda, buffalo grass, and zoysia varieties) are the most common.

The cool-season grasses are better suited to cooler climates, and do not endure hot and dry weather as well as warm-season grasses, but conversely, the warm-season grasses do not grow as well in cooler climates. Most residential lawns are typically seeded with a mixture of these grasses. (A local nursery or lawn center may help you to identify what kind of grass your lawn contains from a sample.)

Knowing your climate and conditions is also important to proper lawn care. Drier climates or conditions will require additional watering, while wetter climates may require more frequent mowing.

## HOW AND WHEN TO WATER, FERTILIZE & AERATE

Every lawn’s watering needs are unique and are dependent upon the type of grass and soil, the amount of local rainfall, and other conditions. **Most lawns are watered too often, but with too little water.** However too much water can allow development of diseases with your lawn. **It is best to water the lawn only when necessary, and then to water it slowly, evenly, and deeply—imitating a slow, soaking rain.**

### WHEN TO WATER YOUR LAWN

When the lawn begins to wilt, the grass’s color dulls, or footprints stay compressed for more than a few seconds, the lawn is beginning to dry out, and needs additional moisture. The best time to water is early morning to allow the water to soak deeply into the lawn and reduce the amount that evaporates in the hot afternoon sun.



### HOW TO WATER YOUR LAWN

The best method of watering a lawn is to imitate a slow, soaking rain, applying about 1 inch of water. A method of verifying the amount that you have watered, is to place several empty tin cans (low shallow cans work best) in various spots around the lawn, and check the depth of water in the can during the watering process.

### HOW TO FERTILIZE YOUR LAWN

Fertilizing with a slow-release fertilizer provides missing nutrients which help create slow, even growth. While opinions vary on the need for fertilizing, when and how much to fertilize will be more a factor of the condition of the lawn and soil than any routine. Remember that over-fertilizing can cause harm, and that most fertilizing should be applied in the spring so that it will release into the lawn through the summer. For more information, check with a local nursery or lawn care specialist, and read and follow the fertilizer manufacturer’s instructions.

### AERATING YOUR LAWN

Consider aerating your lawn in spring. Using an aerator to remove cores of soil from the lawn increases the speed of clipping decomposition and encourages deeper root growth by opening up the soil and permitting greater movement of water, fertilizer and air.



# Lawn Care & Mowing Information

## HOW HIGH TO MOW THE GRASS

Often cutting height is a matter of personal preference. Typically, you should mow the grass when it is between three and five inches high. The proper cutting height range for a specific lawn will depend upon several factors, including the type of grass, the amount of rainfall, the prevailing temperature, and the lawn's overall condition.

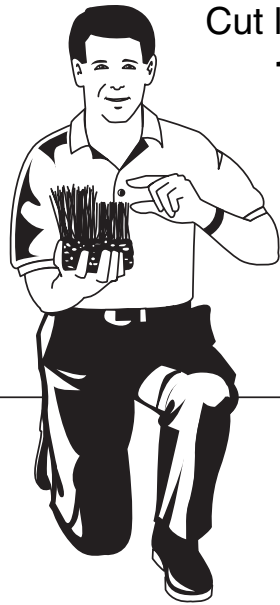
Cutting the grass too short causes weak, thin grass plants, which are easily damaged by dry periods and pests. Cutting too short is often more damaging than allowing the grass to be slightly higher.

Letting grass grow a bit longer—especially when it is hot and dry—reduces heat build-up, preserves needed moisture and protects the grass from heat damage and other problems. However, allowing grass to grow too high can cause thin turf and additional problems.

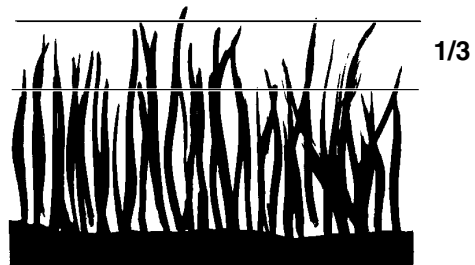
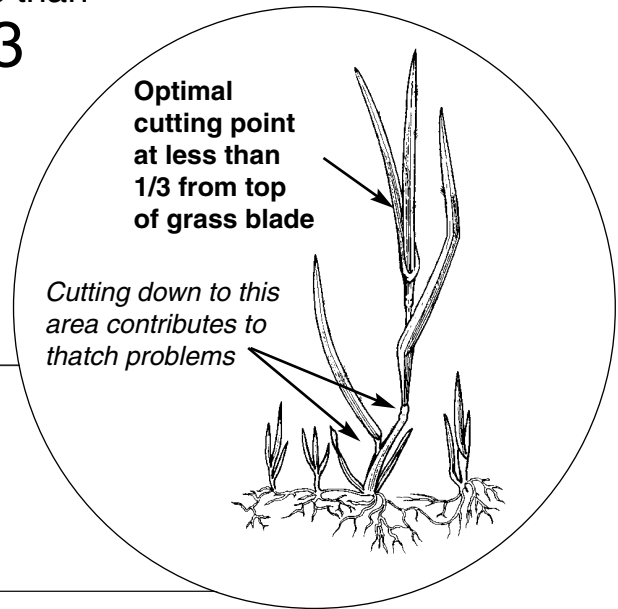
Cutting off too much at one time shocks the plant's growth system and weakens the grass plants. **A good rule of thumb is the 1/3 rule: to cut no more than one third of the grass height, and never more than 1 inch at a time.**

The amount of grass you are able to cut in one pass is also effected by the type of mowing system you are using (for example, broadcasting with side discharge decks can process a much larger volume of grass than mulching does).

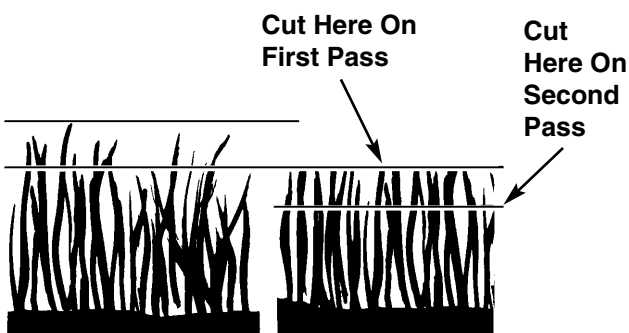
*NOTE: We cover some specific mowing instructions for mulching and broadcasting later in this Lawn Care section.*



Cut less than  
**1/3**



**Proper Cutting Height**

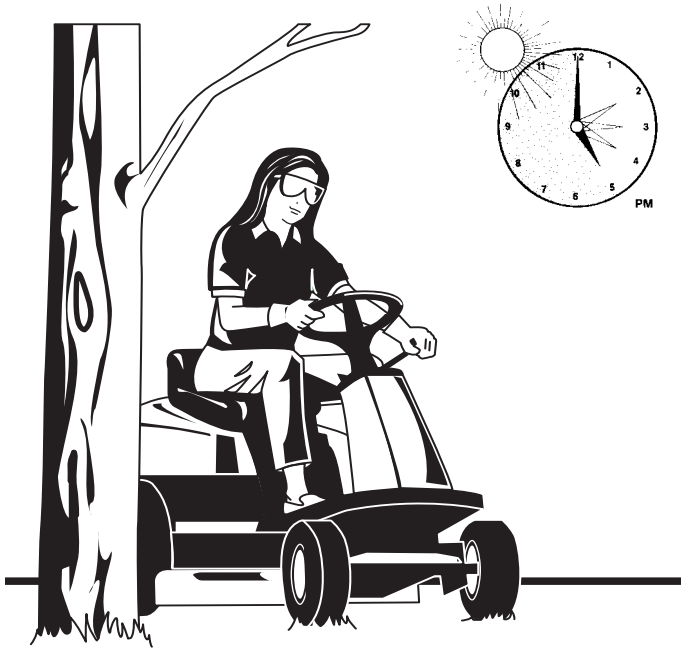


### Tall Grass Requires Incremental Cutting

For extremely tall grass, set the cutting height at maximum for the first pass, and then reset it to the desired height and mow a second or third time.

Don't cover the grass surface with a heavy layer of clippings. Consider using a grass collection system and starting a compost pile.

# Lawn Care & Mowing Information



## WHEN AND HOW OFTEN TO MOW

The time of day and condition of the grass greatly affect the results you'll get when mowing. For the best results, follow these guidelines:

- I Mow when the grass is between three and five inches high.
- I Mow with sharp blades. Short clippings of grass one inch or shorter decompose more quickly than longer blades. Sharp mower blades cut grass cleanly and efficiently, preventing frayed edges which harm the grass.
- I Mow at time of day when the grass is cool and dry. Late afternoon or early evening often provide these ideal mowing conditions.
- I Avoid mowing after rain or even heavy dew, and never mulch when the grass is wet (moist grass does not mulch well, and clumps beneath the mower deck).

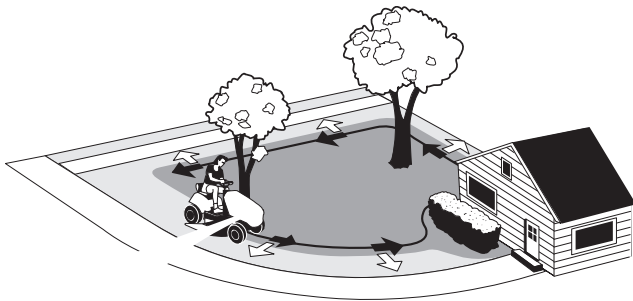
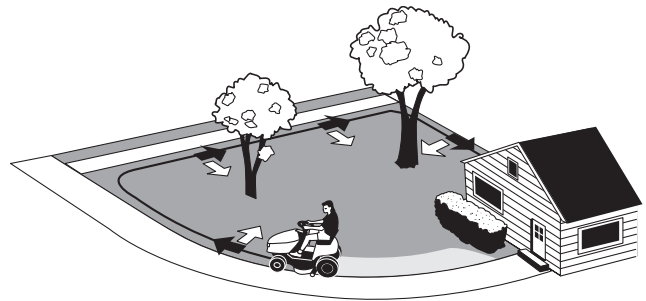
## WHAT MOWING PATTERNS TO USE

Always start mowing on a smooth, level area.

The size and type of area to be mowed will determine the best mowing pattern to use. Obstructions such as trees, fences and buildings, and conditions such as slopes and grades must also be considered.

- I Cut long straight strips overlapping slightly.
- I Where possible, change patterns occasionally to eliminate matting, graining or a corrugated appearance.
- I For a truly professional cut, mow across the lawn in one direction, then recut the lawn by mowing perpendicular to the previous cut.

*Where possible, make one or two passes around the outside of the area discharging the grass INTO the lawn to keep the cut grass off fences and walks.*



*The remainder of the mowing should be done in the opposite direction so that the clippings are dispersed OUT onto the area of lawn previously cut.*

**Note: Always operate the engine at full throttle when mowing.**

If you hear the engine slowing down, you are mowing too fast—using a slower ground speed will improve the cutting efficiency of the blades and prevents many common cutting problems. Use an appropriate ground speed for the thickness and height of the grass you are cutting (3rd gear or slower for manual gear models). If you hear the engine slowing down you are mowing too fast, use a slower ground speed.

# Lawn Care & Mowing Information

---

## MOWING METHODS

---

### Proper Broadcast Mowing

Broadcasting, or side-discharging, disperses fine clippings evenly over the entire lawn. Many golf courses use this method. Your mower has a deep dish deck to allow freer circulation of clippings so they are broadcast evenly over the lawn.

#### ENGINE SPEED & GROUND SPEED FOR BROADCASTING

Always operate the engine at full throttle when mowing. If you hear the engine slowing down, you are mowing too fast—using a slower ground speed will improve the cutting efficiency of the blades and prevents many common cutting problems.

ALWAYS use an appropriate ground speed for the thickness and height of the grass you are cutting (3rd gear or slower for manual gear models). If you hear the engine



slowing down you are mowing too fast, use a slower ground speed.

#### HOW MUCH GRASS TO CUT OFF WHEN BROADCASTING

Mow when the grass is 3-5 inches long. Do not cut the grass shorter than 2 to 2-1/2 inches. Do not cut off more than 1 inch of grass in a single pass.

---

### Proper Mulching

Mulching consists of a mower deck which cuts and recuts clippings into tiny particles and which then blows them down INTO the lawn. These tiny particles decompose rapidly into by-products your lawn can use.

UNDER PROPER CONDITIONS, your mulching mower will virtually eliminate noticeable clippings on the lawn surface.

NOTE: When mulching under heavy cutting conditions, a rumbling sound may be present and is normal.

#### MULCHING REQUIRES EXCELLENT MOWING CONDITIONS

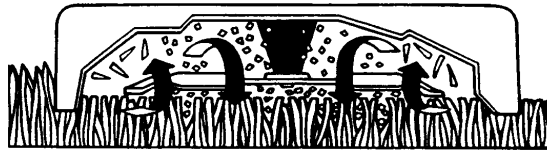
Mulching mowers cannot function properly if the grass is wet, or if the grass is simply high to cut. Even more than normal mowing, mulching requires that the grass be dry and the appropriate amount is cut.

Do not use the mower as a mulching mower during the first two or three mowings in the spring. The long grass blades, quick growth, and often wetter conditions are more suitable for broadcasting (side-discharging) or grass bagging operation.

#### ENGINE SPEED & GROUND SPEED FOR BROADCASTING

Use full engine throttle matched with a slow ground speed so that clippings will be finely cut. Ground speed while mulching should be HALF of the speed that would be used when broadcasting (side discharging) under similar conditions. Since mulching requires more horsepower than broadcasting, using a slower ground speed is vitally important for proper mulching operation.

Mulching Action



#### HOW MUCH GRASS TO MULCH

The best mulching action typically results from cutting only the top 1/2 inch to 3/4 inch of grass blade. This provides short clippings which decompose properly (much more quickly than longer clippings). The ideal cutting

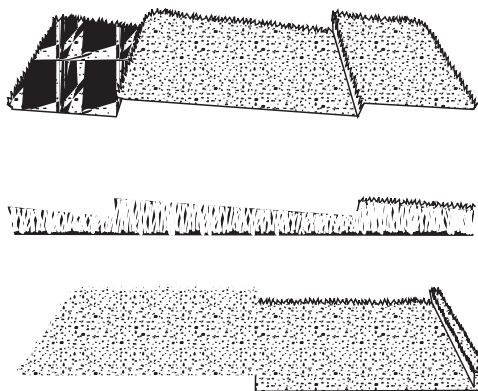
height will vary with climate, time of year, and quality of your lawn. We recommend that you experiment with both the cutting height and ground speed until you achieve the best cut. Start with a high cutting height and using progressively lower settings until you find a cutting height that is matched to your mowing conditions and preferences.



H  
a  
n  
3  
4  
St  
our  
Ph  
is  
Ph  
ek  
the  
V  
C  
D

## Stepped Cutting

Stepped cutting is sharp ridges or uneven levels left in the lawn surface. Stepped cutting is usually caused by mower deck damage or misadjustment, or damage to mower blades.



### CAUSE

- Deck is not leveled correctly
- Tires are not properly inflated
- Blades are damaged
- Deck shell is damaged
- Mower spindle is bent or loose
- Blades are installed incorrectly

### SOLUTION

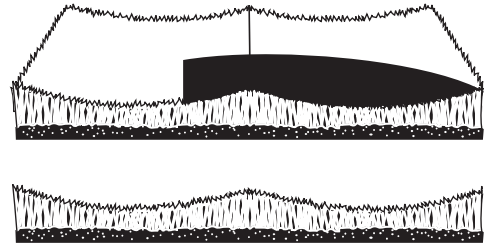
- Level the deck correctly
- Check and inflate the tires
- Replace the blades
- Repair or replace the deck
- Repair or replace the spindle
- Reinstall the blades correctly

# Lawn Care & Mowing Information

## Uneven Cutting

Uneven cutting is waviness or smooth troughs in the lawn surface. Uneven cutting is usually caused by mower deck damage or misadjustment.

## Uneven Cutting



### CAUSE

- Deck is not leveled correctly
- Blades are dull or worn
- Blades are damaged
- Deck is clogged with grass clippings
- Deck shell is damaged
- Mower spindle is bent or loose
- Blades are installed incorrectly

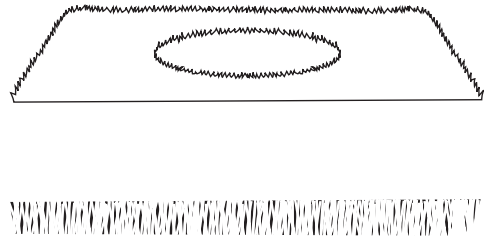
### SOLUTION

- Level the deck correctly
- Sharpen or replace the blades
- Replace the blades
- Clean out the deck
- Repair or replace the deck
- Repair or replace the spindle
- Reinstall the blades correctly

## Scalping

Scalping is when the mower deck comes close to or hits the ground. Scalping can be caused by the mower deck misadjustment, unevenness in the lawn, or by mower deck bouncing because the ground speed is too fast.

## Scalping



### CAUSE

- Lawn is uneven or bumpy
- Mower deck cutting height is set too low
- Ground speed is too fast
- Deck is not leveled correctly
- Tire pressure is low or uneven

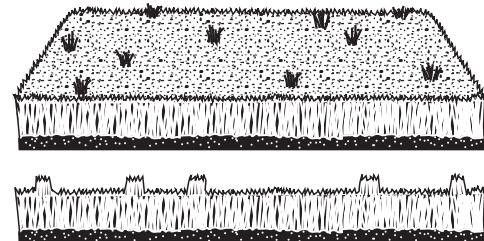
### SOLUTION

- Roll or level the lawn
- Raise the cutting height
- Slow down
- Correctly level the deck
- Check and inflate the tires

## Stingers

Stingers are sparse patches of uncut grass left behind the mower. Stingers are usually caused by operator error or poor blade maintenance.

## Stingers



### CAUSE








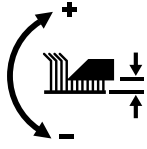


- Blades are not sharp or are nicked
- Blades are worn down too far
- Engine speed is too slow
- Ground speed is too fast
- Deck is plugged with grass

### SOLUTION

- Sharpen your blades
- Replace your blades
- Always mow at full throttle
- Slow down
- Clean out the mower

## Common International Symbols

---

	Choke		PTO Clutch
	Fast (Throttle)		Parking Brake
	Slow (Throttle)		Brake
	Throttle		Mower Cutting Height Adjustment
	Fuel		Headlights

## Technical Manuals

---

### Additional Technical Literature Available

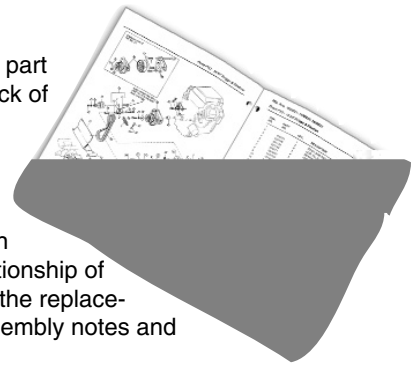


#### **Operators Manuals**

Additional copies of this manual are available, (and as part of our product support commitment, we maintain a stock of printed operators manuals going back many years!)

#### **Parts Manuals**

Fully illustrated parts manuals are also available — these manuals show all of the product's components in exploded views ("3D" illustrations which show the relationship of the parts and how they go together), as well as giving the replacement part numbers and quantities used. Important assembly notes and special torque values are included in these manuals.



*For the applicable manuals currently available for your model, contact your local dealer. Have the information listed in the box at the right available when making your request.*

<b>Model:</b>	_____
<b>Serial No.:</b>	_____
<b>Your Name:</b>	_____
<b>Address:</b>	_____
<b>City, State, Zip:</b>	_____
<b>Visa/Mastercard No.:</b>	_____
<b>Card Expiration Date:</b>	_____





# ***OPERATOR'S MANUAL***

## ***IS5000Z Series***

### ***Zero-Turn Riding Mower***

#### **FERRIS LIMITED WARRANTY**

##### **IMPORTANT**

This warranty shall apply **ONLY** if the warranty registration form has been completed and returned to Ferris Industries, Inc. within 20 days from the date of delivery.

Ferris Industries, Inc. (Ferris) warrants, in accordance with the provisions below, to the original purchaser for the period of twenty-four (24) months from the date of delivery of a Ferris mower that the mower is free from defects in material or workmanship. Ferris' obligation under this warranty is to repair or replace, at Ferris' election, without charge and at the place of business of a dealer authorized to handle Ferris mowers, any part or parts of the machine which, in the judgment of Ferris, prove to be defective.

THIS WARRANTY AND FERRIS' OBLIGATION HEREUNDER IS IN LIEU OF ALL OTHER WARRANTIES, EXPRESSED OR IMPLIED, INCLUDING, WITHOUT LIMITATION, THE IMPLIED WARRANTY OF MERCHANTABILITY OR IMPLIED WARRANTY OF FITNESS FOR PARTICULAR PURPOSE, and all other obligations or liabilities of Ferris for incidental and consequential damages resulting from the design, manufacture, sale or use of the machine. No person is authorized to make any warranty or assume for Ferris any liability not strictly in accordance with this warranty.

This warranty shall not apply to any mower part which, in the judgment of Ferris, has been altered or tampered with in any way or has been subjected to misuse, neglect or accident, or has had the serial numbers altered, effaced or removed. This warranty does not apply to component parts not manufactured by Ferris (motors, batteries, tires, belts) except to the extent of their individual manufacturer's guarantees.

Ferris Industries, Inc. is continually striving to improve its products, and therefore reserves the right to make improvements or change when it becomes practical and possible to do so, without incurring any obligation to make changes or additions to the equipment sold previously.



**Ferris Industries**  
5375 North Main Street  
Munnsville, NY 13409  
800-933-6175

[www.ferrisindustries.com](http://www.ferrisindustries.com)

© Copyright 2004 Ferris Industries  
All Rights Reserved. Printed in USA.

